

powermax600[®]

Plasma Arc Cutting System

***Service Manual
803400 Revision 2***

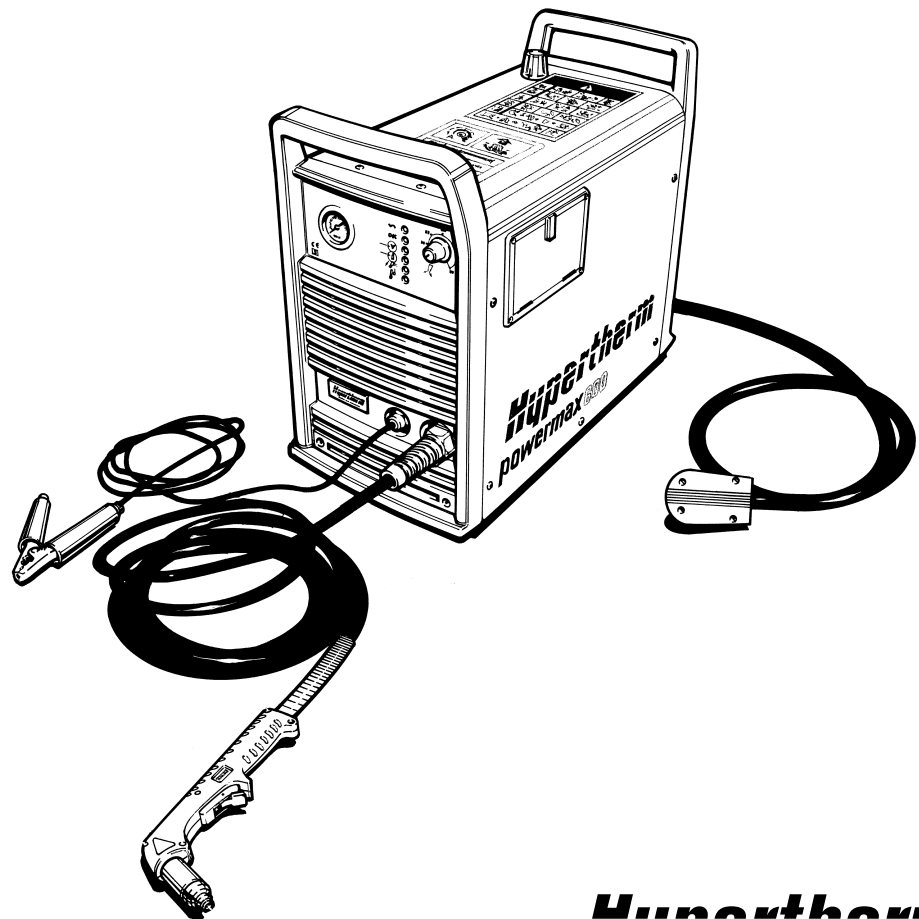

Hypertherm
*The world leader in
plasma cutting technology*

powermax600

Plasma Arc Cutting System

Service Manual IM-340 (P/N 803400)

Revision 2 - NOVEMBER 1999

**Hypertherm, Inc.
Hanover, NH USA
<http://www.hypertherm.com>
[email:info@hypertherm.com](mailto:info@hypertherm.com)**

**© Copyright 1999 Hypertherm, Inc.
All Rights Reserved**

**Hypertherm and Powermax are trademarks of Hypertherm, Inc.
and may be registered in the United States and/or other countries.**

Hypertherm Offices Worldwide:

Hypertherm, Inc.

Etna Road, P.O. Box 5010
Hanover, NH 03755 USA
Tel.: (603) 643-3441 (Main Office)
Fax: (603) 643-5352 (All Departments)
Tel.: (800) 643-9878 (Technical Service)
Tel.: (800) 737-2978 (Customer Service)
email: info@hypertherm.com (General Information)
email: service@hypertherm.com (Technical/Customer Services)

Hypertherm Plasmatechnik GmbH

Technologiepark Hanau
Rodenbacher Chaussee 6
D-63457 Hanau-Wolfgang, Germany
Tel.: 49 6181 58 2100
Fax: 49 6181 58 2134

European Technical Support Organization (ETSO)

Technologiepark Hanau
Rodenbacher Chaussee 6
D-63457 Hanau-Wolfgang, Germany
Tel.: 49 6181 58 2100
Fax: 49 6181 58 2134

Hypertherm Singapore Pte Ltd

No. 19 Kaki Bukit Road 2
K.B. Warehouse Complex
Singapore 417847, Republic of Singapore
Tel.: 65 841 2489
Fax: 65 841 2490

Hypertherm U.K.

9 Berkeley Court • Manor Park
Runcorn, Cheshire, England WA7 1TQ
Tel.: 44 1928 579 074
Fax: 44 1928 579 604

France

10, Allée de l'Isara
F-95000 Cergy-Pontoise, France
Tel.: 33 1 34 24 03 05
Fax: 33 1 34 25 09 64

Italy

Via Torino 2
20123 Milan, Italy
Tel.: 39 02 725 46 312
Fax: 39 02 725 46 400

The Netherlands

Burg, Haverkampstraat 13
7091 CN Dinxperlo, Holland
Tel.: 31 315 655866
Fax: 31 315 655886

EMC INTRODUCTION

The CE power supplies have been built in compliance with standard EN50199. To ensure that the equipment works in a compatible manner with other radio and electronic systems, the equipment should be installed and used in accordance with the information below to achieve electromagnetic compatibility.

The limits required by EN50199 may not be adequate to completely eliminate interference when the affected equipment is in close proximity or has a high degree of sensitivity. In such cases it may be necessary to use other measures to further reduce interference.

This plasma equipment should be used only in an industrial environment. It may be difficult to ensure electromagnetic compatibility in a domestic environment.

INSTALLATION AND USE

The user is responsible for installing and using the plasma equipment according to the manufacturer's instructions. If electromagnetic disturbances are detected then it shall be the responsibility of the user to resolve the situation with the technical assistance of the manufacturer. In some cases this remedial action may be as simple as earthing the cutting circuit, see *Earthing of Workpiece*. In other cases it could involve constructing an electromagnetic screen enclosing the power source and the work complete with associated input filters. In all cases electromagnetic disturbances must be reduced to the point where they are no longer troublesome.

ASSESSMENT OF AREA

Before installing the equipment the user shall make an assessment of potential electromagnetic problems in the surrounding area. The following shall be taken into account:

- Other supply cables, control cables, signalling and telephone cables; above, below and adjacent to the cutting equipment.
- Radio and television transmitters and receivers.
- Computer and other control equipment.
- Safety critical equipment, for example guarding of industrial equipment.

e. Health of the people around, for example the use of pacemakers and hearing aids.

f. Equipment used for calibration or measurement.

g. Immunity of other equipment in the environment. User shall ensure that other equipment being used in the environment is compatible. This may require additional protection measures.

h. Time of day that cutting or other activities are to be carried out.

The size of the surrounding area to be considered will depend on the structure of the building and other activities that are taking place. The surrounding area may extend beyond the boundaries of the premises.

METHODS OF REDUCING EMISSIONS

Mains Supply

Cutting equipment should be connected to the mains supply according to the manufacturer's recommendations. If interference occurs, it may be necessary to take additional precautions such as filtering of the mains supply. Consideration should be given to shielding the supply cable of permanently installed cutting equipment, in metallic conduit or equivalent. Shielding should be electrically continuous throughout its length. The shielding should be connected to the cutting mains supply so that good electrical contact is maintained between the conduit and the cutting power source enclosure.

Maintenance of Cutting Equipment

The cutting equipment should be routinely maintained according to the manufacturer's recommendations. All access and service doors and covers should be closed and properly fastened when the cutting equipment is in operation. The cutting equipment should not be modified in any way except for those changes and adjustments covered in the manufacturer's instructions. In particular, the spark gaps of arc striking and stabilizing devices should be adjusted and maintained according to the manufacturer's recommendations.

Cutting Cables

The cutting cables should be kept as short as possible and should be positioned close together, running at or close to the floor level.

Equipotential Bonding

Bonding of all metallic components in the cutting installation and adjacent to it should be considered. However, metallic components bonded to the workpiece will increase the risk that the operator could receive a shock by touching these metallic components and the electrode at the same time. The operator should be insulated from all such bonded metallic components.

Earthing of Workpiece

Where the workpiece is not bonded to earth for electrical safety, nor connected to earth because of its size and position, for example, ship's hull or building steelwork, a connection bonding the workpiece to earth may reduce emissions in some, but not all instances. Care should be taken to prevent the earthing of the workpiece increasing the risk of injury to users, or damage to other electrical equipment. Where necessary, the connection of the workpiece to earth should be made by a direct connection to the workpiece, but in some countries where direct connection is not permitted, the bonding should be achieved by suitable capacitances selected according to national regulations.

Note: The cutting circuit may or may not be earthed for safety reasons. Changing the earthing arrangements should only be authorized by a person who is competent to assess whether the changes will increase the risk of injury, for example, by allowing parallel cutting current return paths which may damage the earth circuits of other equipment. Further guidance is given in IEC TC26 (sec)94 and IEC TC26/108A/CD Arc Welding Equipment Installation and Use.

Screening and Shielding

Selective screening and shielding of other cables and equipment in the surrounding area may alleviate problems of interference. Screening of the entire plasma cutting installation may be considered for special applications.



WARNING

Genuine Hypertherm parts are the factory-recommended replacement parts for your Hypertherm system. Any damage caused by the use of other than genuine Hypertherm parts may not be covered by the Hypertherm warranty.

GENERAL

Hypertherm, Inc. warrants that products shall be free from defects in materials and workmanship, under proper and normal use for which such equipment is recommended, for a period of two (2) years, except only with respect to the torch, for which the warranty period shall be one (1) year, from the date of its delivery to you.

Hypertherm, at its sole option, shall repair, replace, or adjust, free of charge, any Products covered by this warranty which shall be returned with Hypertherm's prior authorization (which shall not be unreasonably withheld), properly packed, to Hypertherm's place of business in Hanover, New Hampshire, all costs, insurance and freight prepaid, and which examination proves not to be free from defects in materials and workmanship. Hypertherm shall not be liable for any repairs, replacements, or adjustments of Products covered by this warranty, except those made pursuant to this paragraph or with Hypertherm's written consent. This warranty shall not apply to any Product which has been mishandled, incorrectly installed, modified or assembled by you or any other person. Hypertherm shall be liable for breach of this warranty only if it receives written notice of such breach within the applicable warranty period specified herein above. THE FOREGOING SHALL CONSTITUTE THE SOLE REMEDY TO DISTRIBUTORS OR THEIR CUSTOMERS FOR ANY BREACH BY HYPERTHERM OF ITS WARRANTY.

PATENT INDEMNITY

Except only in cases of Products not manufactured by Hypertherm or manufactured by a person other than Hypertherm not in strict conformity with Hypertherm's specifications, and in cases of designs, processes, formulae or combinations not developed or purported to be developed by Hypertherm, Hypertherm agrees to indemnify, protect and hold harmless Distributors and their customers against any and all liability or claims in any manner imposed upon or accruing against Distributors and their customers because of the use in or about the construction or operation of equipment or any design, system, formula, combination, article or material which infringes or alleges to infringe on

any patent or other right. Distributors shall notify Hypertherm promptly upon learning of any action or threatened action in connection with any such alleged infringement, and each party may appoint its own counsel for any such action or threatened action.

DISCLAIMER OF OTHER WARRANTIES

HYPERTHERM MAKES NO WARRANTIES REGARDING PRODUCTS MANUFACTURED BY IT OR OTHERS (INCLUDING WITHOUT IMPLIED LIMITATION WARRANTIES AS TO MERCHANTABILITY OR FITNESS FOR A PARTICULAR PURPOSE), EITHER EXPRESS OR IMPLIED, EXCEPT AS PROVIDED HEREIN. This warranty is in lieu of any and all warranties, express or implied, by law or otherwise; and Distributors are not authorized to give any other warranty purporting to be binding upon Hypertherm upon resale of Products to their customers. IN NO EVENT shall Hypertherm be liable for incidental or consequential damages or injury to the person or property of anyone by reason of any defect in any Equipment sold hereunder.

UPON RECEIPT

1. Verify that all parts and items on your order have been received. Alert your distributor if any parts or items are damaged or missing.
2. Inspect the power supply for any physical damage that may have occurred during shipping. If there is evidence of damage, refer to the *Claims* section below. All communications regarding this equipment must include the model number and serial number located on the back of the Powermax600.
3. Before setting up and operating the Powermax600, read the Safety section of this manual.

CLAIMS

Claims for damage during shipment — If your unit was damaged during shipment, you must file a claim with the carrier. Hypertherm will furnish you with a copy of the bill of lading upon request. If you need additional assistance, call Customer Service listed in the front of this manual, or your authorized Hypertherm distributor.

Claims for defective or missing merchandise — If any of the merchandise is defective or missing, call your authorized Hypertherm distributor. If you need additional assistance, call Customer Service listed in the front of this manual.

TABLE OF CONTENTS

Electromagnetic Compatibility	i
Warranty	ii

SECTION 1 - SAFETY

RECOGNIZE SAFETY INFORMATION	1-2
FOLLOW SAFETY INSTRUCTIONS	1-2
CUTTING CAN CAUSE FIRE OR EXPLOSION	1-2
ELECTRIC SHOCK CAN KILL	1-3
CUTTING CAN PRODUCE TOXIC FUMES	1-3
PLASMA ARC CAN CAUSE INJURY AND BURNS	1-4
ARC RAYS CAN BURN EYES AND SKIN	1-4
GROUNDING SAFETY	1-4
COMPRESSED GAS EQUIPMENT SAFETY	1-5
GAS CYLINDERS CAN EXPLODE IF DAMAGED	1-5
NOISE CAN DAMAGE HEARING	1-5
PACEMAKER AND HEARING AID OPERATION	1-5
ADDITIONAL SAFETY INFORMATION	1-5
WARNING LABEL	1-6

SECTION 1a - SÉCURITÉ

IDENTIFIER LES CONSIGNES DE SÉCURITÉ	1a-2
SUIVRE LES INSTRUCTIONS DE SÉCURITÉ	1a-2
LE COUPAGE PEUT PROVOQUER UN INCENDIE OU UNE EXPLOSION	1a-2
LES CHOCS ÉLECTRIQUES PEUVENT ÊTRE FATALES	1a-3
LE COUPAGE PEUT PRODUIRE DES VAPEURS TOXIQUES	1a-3
L'ARC PLASMA PEUT PROVOQUER DES BLESSURES OU DES BRÛLURES	1a-4
LES RAYONS DE L'ARC PEUVENT BRÛLER LES YEUX ET LA PEAU	1a-4
MISE À LA MASSE ET À LA TERRE	1a-4
SÉCURITÉ DES BOUTEILLES DE GAZ COMPRIMÉ	1a-5
LES BOUTEILLES DE GAZ COMPRIMÉ PEUVENT EXPLOSER EN CAS DE DOMMAGES	1a-5
LE BRUIT PEUT PROVOQUER DES PROBLÈMES AUDITIFS	1a-5
PACEMAKERS ET PROTHÈSES AUDITIVES	1a-5
ÉTIQUETTE DE SÉCURITÉ	1a-6

SECTION 2 SPECIFICATIONS

SPECIFICATIONS, POWER SUPPLY	2-2
SPECIFICATIONS, PAC123 TORCHES	2-3
SETUP SPECIFICATIONS	2-4
INSTALL POWER CORD PLUG	2-4
CHECK REQUIRED INPUT VOLTAGE	2-4
S MARK (230/400 VOLT ONLY)	2-4
GROUNDING REQUIREMENTS	2-5
POWER CORD / EXTENSION CORD	2-5
GAS REQUIREMENTS	2-6
LINE VOLTAGE DISCONNECT BOX	2-6

TABLE OF CONTENTS

SECTION 3 MAINTENANCE

CONTROLS AND INDICATORS	3-2
INDICATOR LAMPS	3-2
CONTROLS	3-2
THEORY OF OPERATION	3-3
GENERAL	3-3
230/400 VOLT FUNCTIONAL DESCRIPTION	3-4
208-240/480 VOLT FUNCTIONAL DESCRIPTION	3-6
SEQUENCE OF OPERATION	3-8
TROUBLESHOOTING	3-9
TEST EQUIPMENT	3-9
TROUBLESHOOTING PROCEDURES AND SEQUENCE	3-9
VISUAL INSPECTION - EXTERNAL	3-9
VISUAL INSPECTION - INTERNAL	3-10
RESISTANCE CHECKS	3-11
TROUBLESHOOTING GUIDE	3-14
VOLTAGE CHECKS	3-21
COMPONENT REPLACEMENT	3-26
POWER CORD REPLACEMENT	3-26
TORCH LEAD REPLACEMENT (MODELS WITHOUT QUICK DISCONNECT)	3-27
AIR FILTER ELEMENT REPLACEMENT	3-28
WORK CABLE REPLACEMENT	3-30
CAPACITOR REPLACEMENT	3-31
HEAT SINK COMPONENT REPLACEMENT	3-32

SECTION 4 PARTS LIST - 400/230V CE

POWER SUPPLY – EXTERIOR	4-2
POWER SUPPLY – FRONT INTERIOR RIGHT SIDE	4-3
POWER SUPPLY – BACK INTERIOR RIGHT SIDE	4-4
POWER SUPPLY – INTERIOR FAN SIDE	4-5
POWER SUPPLY – HEAT SINK ASSEMBLY	4-6
RECOMMENDED SPARE PARTS - POWERMAX600- 230/400V	4-7

SECTION 5 PARTS LIST - 208-240/480V

POWER SUPPLY – EXTERIOR	5-2
POWER SUPPLY – FRONT INTERIOR RIGHT SIDE	5-3
POWER SUPPLY – BACK INTERIOR RIGHT SIDE	5-4
POWER SUPPLY – INTERIOR FAN SIDE	5-5
POWER SUPPLY – HEAT SINK ASSEMBLY	5-6
RECOMMENDED SPARE PARTS - POWERMAX600- 208-240/480V	5-7

SECTION 6 PARTS LIST - TORCH AND CONSUMABLES

PAC123T HAND TORCH ASSEMBLY (NO QUICK DISCONNECT)	6-2
PAC123T HAND TORCH ASSEMBLY (WITH QUICK DISCONNECT)	6-4
PAC123M MACHINE TORCH ASSEMBLY (NO QUICK DISCONNECT)	6-6
PAC123M MACHINE TORCH ASSEMBLY (WITH QUICK DISCONNECT)	6-8
TORCH CONSUMABLES	6-10
RECOMMENDED SPARE PARTS - PAC123 TORCH	6-11

SECTION 7 WIRING DIAGRAMS

Section 1

SAFETY

In this section:

Recognize Safety Information	1-2
Follow Safety Instructions	1-2
Cutting Can Cause Fire or Explosion	1-2
Electric Shock Can Kill	1-3
Cutting Can Produce Toxic Fumes	1-3
Plasma Arc Can Cause Injury and Burns	1-4
Arc Rays Can Burn Eyes and Skin	1-4
Grounding Safety	1-4
Compressed Gas Equipment Safety	1-5
Gas Cylinders Can Explode if Damaged	1-5
Noise Can Damage Hearing	1-5
Pacemaker and Hearing Aid Operation	1-5
Additional Safety Information	1-5
Warning Label	1-6



RECOGNIZE SAFETY INFORMATION

The symbols shown in this section are used to identify potential hazards. When you see a safety symbol in this manual or on your machine, understand the potential for personal injury, and follow the related instructions to avoid the hazard.



FOLLOW SAFETY INSTRUCTIONS

Read carefully all safety messages in this manual and safety labels on your machine.

- Keep the safety labels on your machine in good condition. Replace missing or damaged labels immediately.
- Learn how to operate the machine and how to use the controls properly. Do not let anyone operate it without instruction.

- Keep your machine in proper working condition. Unauthorized modifications to the machine may affect safety and machine service life.

DANGER WARNING CAUTION

A signal word DANGER or WARNING is used with a safety symbol. DANGER identifies the most serious hazards.

- DANGER and WARNING safety labels are located on your machine near specific hazards.
- WARNING safety messages precede related instructions in this manual that may result in injury or death if not followed correctly.
- CAUTION safety messages precede related instructions in this manual that may result in damage to equipment if not followed correctly.



CUTTING CAN CAUSE FIRE OR EXPLOSION

Fire Prevention

- Be sure the area is safe before doing any cutting. Keep a fire extinguisher nearby.
- Remove all flammables within 35 feet (10 m) of the cutting area.
- Quench hot metal or allow it to cool before handling or before letting it touch combustible materials.
- Never cut containers with potentially flammable materials inside – they must be emptied and properly cleaned first.
- Ventilate potentially flammable atmospheres before cutting.
- When cutting with oxygen as the plasma gas, an exhaust ventilation system is required.

Explosion Prevention

- Do not use the plasma system if explosive dust or vapors may be present.
- Do not cut pressurized cylinders, pipes, or any closed container.
- Do not cut containers that have held combustible materials.



WARNING

Explosion Hazard
Argon-Hydrogen and Methane

Hydrogen and methane are flammable gases that present an explosion hazard. Keep flames away from cylinders and hoses that contain methane or hydrogen mixtures. Keep flames and sparks away from the torch when using methane or argon-hydrogen plasma.



WARNING

Hydrogen Detonation with Aluminum Cutting

- When cutting aluminum underwater, or with the water touching the underside of the aluminum, free hydrogen gas may collect under the workpiece and detonate during plasma cutting operations.
- Install an aeration manifold on the floor of the water table to eliminate the possibility of hydrogen detonation. Refer to the Appendix section of this manual for aeration manifold details.



ELECTRIC SHOCK CAN KILL

Touching live electrical parts can cause a fatal shock or severe burn.

- Operating the plasma system completes an electrical circuit between the torch and the workpiece. The workpiece and anything touching the workpiece are part of the electrical circuit.
- Never touch the torch body, workpiece or the water in a water table when the plasma system is operating.

Electric Shock Prevention

All Hypertherm plasma systems use high voltage in the cutting process (200 to 400 VDC are common). Take the following precautions when operating this system:

- Wear insulated gloves and boots, and keep your body and clothing dry.
- Do not stand, sit or lie on – or touch – any wet surface when using the plasma system.
- Insulate yourself from work and ground using dry insulating mats or covers big enough to prevent any physical contact with the work or ground. If you must work in or near a damp area, use extreme caution.
- Provide a disconnect switch close to the power supply with properly sized fuses. This switch allows the operator to turn off the power supply quickly in an emergency situation.
- When using a water table, be sure that it is correctly connected to earth ground.
- Install and ground this equipment according to the instruction manual and in accordance with national and local codes.
- Inspect the input power cord frequently for damage or cracking of the cover. Replace a damaged power cord immediately. **Bare wiring can kill.**
- Inspect and replace any worn or damaged torch leads.
- Do not pick up the workpiece, including the waste cutoff, while you cut. Leave the workpiece in place or on the workbench with the work cable attached during the cutting process.
- Before checking, cleaning or changing torch parts, disconnect the main power or unplug the power supply.
- Never bypass or shortcut the safety interlocks.
- Before removing any power supply or system enclosure cover, disconnect electrical input power. Wait 5 minutes after disconnecting the main power to allow capacitors to discharge.
- Never operate the plasma system unless the power supply covers are in place. Exposed power supply connections present a severe electrical hazard.
- When making input connections, attach proper grounding conductor first.
- Each Hypertherm plasma system is designed to be used only with specific Hypertherm torches. Do not substitute other torches which could overheat and present a safety hazard.



CUTTING CAN PRODUCE TOXIC FUMES

Cutting can produce toxic fumes and gases that deplete oxygen and cause injury or death.

- Keep the cutting area well ventilated or use an approved air-supplied respirator.
- Do not cut in locations near degreasing, cleaning or spraying operations. The vapors from certain chlorinated solvents decompose to form phosgene gas when exposed to ultraviolet radiation.
- Do not cut metal coated or containing toxic materials, such as zinc (galvanized), lead, cadmium or beryllium, unless the area is well ventilated and the operator wears an air-supplied respirator. The coatings and any metals containing these elements can produce toxic fumes when cut.
- Never cut containers with potentially toxic materials inside – they must be emptied and properly cleaned first.
- This product, when used for welding or cutting, produces fumes or gases which contain chemicals known to the State of California to cause birth defects and, in some cases, cancer.



PLASMA ARC CAN CAUSE INJURY AND BURNS

Instant-On Torches

Plasma arc comes on immediately when the torch switch is activated.

The plasma arc will cut quickly through gloves and skin.

- Keep away from the torch tip.
- Do not hold metal near the cutting path.
- Never point the torch toward yourself or others.



ARC RAYS CAN BURN EYES AND SKIN

Eye Protection Plasma arc rays produce intense visible and invisible (ultraviolet and infrared) rays that can burn eyes and skin.

- Use eye protection in accordance with applicable national or local codes.
- Wear eye protection (safety glasses or goggles with side shields, or a welding helmet) with appropriate lens shading to protect your eyes from the arc's ultraviolet and infrared rays.

Skin Protection Wear protective clothing to protect against burns caused by ultraviolet light, sparks and hot metal.

- Gauntlet gloves, safety shoes and hat.
- Flame-retardant clothing to cover all exposed areas.
- Cuffless trousers to prevent entry of sparks and slag.
- Remove any combustibles, such as a butane lighter or matches, from your pockets before cutting.

Arc Current		Lens Shade	
		AWS (USA)	ISO 4850
Up to 100 A		No. 8	No. 11
100-200 A		No. 10	No. 11-12
200-400 A		No. 12	No. 13
Over 400 A		No. 14	No. 14

Cutting Area Prepare the cutting area to reduce reflection and transmission of ultraviolet light:

- Paint walls and other surfaces with dark colors to reduce reflection.
- Use protective screens or barriers to protect others from flash and glare.
- Warn others not to watch the arc. Use placards or signs.



GROUNDING SAFETY

Work Cable Attach the work cable securely to the workpiece or the work table with good metal-to-metal contact. Do not connect it to the piece that will fall away when the cut is complete.

Work Table Connect the work table to an earth ground, in accordance with appropriate national or local electrical codes.

Input Power

- Be sure to connect the power cord ground wire to the ground in the disconnect box.
- If installation of the plasma system involves connecting the power cord to the power supply, be sure to connect the power cord ground wire properly.
- Place the power cord's ground wire on the stud first, then place any other ground wires on top of the power cord ground. Fasten the retaining nut tightly.
- Tighten all electrical connections to avoid excessive heating.

COMPRESSED GAS EQUIPMENT SAFETY

- Never lubricate cylinder valves or regulators with oil or grease.
- Use only correct gas cylinders, regulators, hoses and fittings designed for the specific application.
- Maintain all compressed gas equipment and associated parts in good condition.
- Label and color-code all gas hoses to identify the type of gas in each hose. Consult applicable national or local codes.

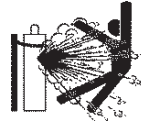
**GAS CYLINDERS CAN EXPLODE IF DAMAGED**

Gas cylinders contain gas under high pressure. If damaged, a cylinder can explode.

- Handle and use compressed gas cylinders in accordance with applicable national or local codes.
- Never use a cylinder that is not upright and secured in place.
- Keep the protective cap in place over valve except when the cylinder is in use or connected for use.
- Never allow electrical contact between the plasma arc and a cylinder.
- Never expose cylinders to excessive heat, sparks, slag or open flame.
- Never use a hammer, wrench or other tool to open a stuck cylinder valve.

**NOISE CAN DAMAGE HEARING**

Prolonged exposure to noise from cutting or gouging can damage hearing.

- Use approved ear protection when using plasma system.
- Warn others nearby about the noise hazard.

**PACEMAKER AND HEARING AID OPERATION**

Pacemaker and hearing aid operation can be affected by magnetic fields from high currents.

Pacemaker and hearing aid wearers should consult a doctor before going near any plasma arc cutting and gouging operations.

To reduce magnetic field hazards:

- Keep both the work cable and the torch lead to one side, away from your body.
- Route the torch leads as close as possible to the work cable.
- Do not wrap or drape the torch lead or work cable around your body.
- Keep as far away from the power supply as possible.

ADDITIONAL SAFETY INFORMATION

1. ANSI Standard Z49.1, *Safety in Welding and Cutting*, American Welding Society, 550 LeJeune Road, P.O. Box 351020, Miami, FL 33135
2. ANSI Standard Z49.2, *Fire Prevention in the Use of Cutting and Welding Processes*, American National Standards Institute, 1430 Broadway, New York, NY 10018
3. ANSI Standard Z87.1, *Safe Practices for Occupation and Educational Eye and Face Protection*, American National Standards Institute, 1430 Broadway, New York, NY 10018
4. AWS F4.1, *Recommended Safe Practices for the Preparation for Welding and Cutting of Containers and Piping That Have Held Hazardous Substances*, American Welding Society, 550 LeJeune Road, P.O. Box 351040, Miami, FL 33135
5. AWS F5.2, *Recommended Safe Practices for Plasma Arc Cutting*, American Welding Society, 550 LeJeune Road, P.O. Box 351040, Miami, FL 33135
6. CGA Pamphlet P-1, *Safe Handling of Compressed Gases in Cylinders*, Compressed Gas Association, 1235 Jefferson Davis Highway, Arlington, VA 22202
7. CSA Standard W117.2, *Code for Safety in Welding and Cutting*, Canadian Standards Association Standard Sales, 178 Rexdale Boulevard, Rexdale, Ontario M9W 1R3, Canada
8. NFPA Standard 51B, *Cutting and Welding Processes*, National Fire Protection Association, 470 Atlantic Avenue, Boston, MA 02210
9. NFPA Standard 70-1978, *National Electrical Code*, National Fire Protection Association, 470 Atlantic Avenue, Boston, MA 02210
10. OSHA, *Safety and Health Standards*, 29FR 1910, U.S. Government Printing Office, Washington, D.C. 20402

WARNING LABEL

This warning label is affixed to some power supplies. It is important that the operator and maintenance technician understand the intent of these warning symbols as described. The numbered text corresponds to the numbered boxes on the label.



1. Cutting sparks can cause explosion or fire.
 - 1.1 Keep flammables away from cutting.
 - 1.2 Keep a fire extinguisher nearby, and have a watchperson ready to use it.
 - 1.3 Do not cut on any closed containers.
2. The plasma arc can cause injury and burns.
 - 2.1 Turn off power before disassembling torch.
 - 2.2 Do not hold the material near cutting path.
 - 2.3 Wear complete body protection.
3. Electric shock from torch or wiring can kill. Protect yourself from electric shock.
 - 3.1 Wear insulating gloves. Do not wear wet or damaged gloves.
 - 3.2 Insulate yourself from work and ground.
 - 3.3 Disconnect input plug or power before working on machine.
4. Breathing cutting fumes can be hazardous to your health.
 - 4.1 Keep your head out of the fumes.
 - 4.2 Use forced ventilation or local exhaust to remove the fumes.
 - 4.3 Use ventilating fan to remove the fumes.
5. Arc rays can burn eyes and injure skin.
 - 5.1 Wear hat and safety glasses. Use ear protection and button shirt collar. Use welding helmet with correct shade of filter. Wear complete body protection.
6. Become trained and read the instructions before working on the machine or cutting.
7. Do not remove or paint over (cover) warning labels.

Section 1a

SÉCURITÉ

Cette section comprend:

IDENTIFIER LES CONSIGNES DE SÉCURITÉ	1a-2
SUIVRE LES INSTRUCTIONS DE SÉCURITÉ	1a-2
LE COUPAGE PEUT PROVOQUER UN INCENDIE OU UNE EXPLOSION ..	1a-2
LES CHOCS ÉLECTRIQUES PEUVENT ÊTRE FATALS	1a-3
LE COUPAGE PEUT PRODUIRE DES VAPEURS TOXIQUES	1a-3
L'ARC PLASMA PEUT PROVOQUER DES BLESSURES OU DES BRÛLURES	1a-4
LES RAYONS DE L'ARC PEUVENT BRÛLER LES YEUX ET LA PEAU	1a-4
MISE À LA MASSE ET À LA TERRE	1a-4
SÉCURITÉ DES BOUTEILLES DE GAZ COMPRIMÉ	1a-5
LES BOUTEILLES DE GAZ COMPRIMÉ PEUVENT EXPLOSER EN CAS DE DOMMAGES	1a-5
LE BRUIT PEUT PROVOQUER DES PROBLÈMES AUDITIFS	1a-5
PACEMAKERS ET PROTHÈSES AUDITIVES	1a-5
ÉTIQUETTE DE SÉCURITÉ	1a-6

**IDENTIFIER LES CONSIGNES DE SÉCURITÉ**

Les symboles indiqués dans cette section sont utilisés pour identifier les risques éventuels. Si vous trouvez un symbole de sécurité, que ce soit dans ce manuel ou sur l'équipement, soyez conscient des risques de blessures et suivez les instructions correspondantes afin d'éviter ces risques.

**SUIVRE LES INSTRUCTIONS DE SÉCURITÉ**

Lire attentivement toutes les consignes de sécurité dans le présent manuel et sur les étiquettes de sécurité se trouvant sur la machine.

- Les étiquettes de sécurité doivent rester lisibles. Remplacer immédiatement les étiquettes manquantes ou abîmées.
- Apprendre à faire fonctionner la machine et à utiliser correctement les commandes. Ne laisser personne utiliser la machine sans connaître son fonctionnement.

- Garder la machine en bon état. Des modifications non autorisées sur la machine peuvent engendrer des problèmes de sécurité et raccourcir la durée d'utilisation de l'équipement.

DANGER AVERTISSEMENT PRÉCAUTION

Les signaux DANGER ou AVERTISSEMENT sont utilisés avec un symbole de sécurité, DANGER correspondant aux risques les plus sérieux.

- Les étiquettes de sécurité DANGER et AVERTISSEMENT sont situées sur la machine pour signaler certains dangers spécifiques.
- Les messages d'AVERTISSEMENT précèdent les instructions d'utilisation expliquées dans ce manuel et signalent les risques de blessures ou de mort au cas où ces instructions ne seraient pas suivies correctement.
- Les messages de PRÉCAUTION précèdent les instructions d'utilisation contenues dans ce manuel et signalent que le matériel risque d'être endommagé si les instructions ne sont pas suivies correctement.

**LE COUPAGE PEUT PROVOQUER UN INCENDIE OU UNE EXPLOSION****Prévention des incendies**

- Avant de commencer, s'assurer que la zone de coupage ne présente aucun danger. Conserver un extincteur à proximité.
- Éloigner toute matière inflammable à une distance d'au moins 10 m du poste de coupage.
- Tremper le métal chaud ou le laisser refroidir avant de le manipuler ou avant de le mettre en contact avec des matériaux combustibles.
- Ne jamais couper des récipients pouvant contenir des matières inflammables avant de les avoir vidés et nettoyés correctement.
- Aérer toute atmosphère potentiellement inflammable avant d'utiliser un système plasma.
- Lors de l'utilisation d'oxygène comme gaz plasma, un système de ventilation par aspiration est nécessaire.

Prévention des explosions

- Ne pas couper en présence de poussière ou de vapeurs.
- Ne pas couper de bouteilles, de tuyaux ou autres récipients fermés et pressurisés.
- Ne pas couper de récipients contenant des matières combustibles.

**AVERTISSEMENT**

Risque d'explosion
Argon-hydrogène et méthane

L'hydrogène et le méthane sont des gaz inflammables et potentiellement explosifs. Conserver à l'écart de toute flamme les bouteilles et tuyaux contenant des mélanges à base d'hydrogène ou de méthane. Maintenir toute flamme et étincelle à l'écart de la torche lors de l'utilisation d'un plasma d'argon-hydrogène ou de méthane.

**AVERTISSEMENT**

Détonation de l'hydrogène lors du coupage de l'aluminium

- Lors du coupage de l'aluminium sous l'eau, ou si l'eau touche la partie inférieure de la pièce d'aluminium, de l'hydrogène libre peut s'accumuler sous la pièce à couper et détonner lors du coupage plasma.
- Installer un collecteur d'aération au fond de la table à eau afin d'éliminer les risques de détonation de l'hydrogène. Se référer à l'annexe du manuel pour plus de renseignements sur les collecteurs d'aération.



LES CHOCs ÉLECTRIQUES PEUVENT ÊTRE FATALS

Toucher une pièce électrique sous tension peut provoquer un choc électrique fatal ou des brûlures graves.

- La mise en fonctionnement du système plasma ferme un circuit électrique entre la torche et la pièce à couper. La pièce à couper et tout autre élément en contact avec cette pièce font partie du circuit électrique.
- Ne jamais toucher le corps de la torche, la pièce à couper ou l'eau de la table à eau pendant le fonctionnement du système plasma.

Prévention des chocs électriques

Tous les systèmes plasma Hypertherm utilisent des hautes tensions pour le coupage (souvent de 200 à 400 V). On doit prendre les précautions suivantes quand on utilise le système plasma :

- Porter des bottes et des gants isolants et garder le corps et les vêtements au sec.
- Ne pas se tenir, s'asseoir ou se coucher sur une surface mouillée, ni la toucher quand on utilise le système plasma.
- S'isoler de la surface de travail et du sol en utilisant des tapis isolants secs ou des couvertures assez grandes pour éviter tout contact physique avec le travail ou le sol. S'il s'avère nécessaire de travailler dans ou près d'un endroit humide, procéder avec une extrême prudence.
- Installer un sectionneur avec fusibles appropriés, à proximité de la source de courant. Ce dispositif permet à l'opérateur d'arrêter rapidement la source de courant en cas d'urgence.
- En cas d'utilisation d'une table à eau, s'assurer que cette dernière est correctement mise à la terre.

- Installer et mettre à la terre l'équipement selon les instructions du présent manuel et conformément aux codes électriques locaux et nationaux.
- Inspecter fréquemment le cordon d'alimentation primaire pour s'assurer qu'il n'est ni endommagé, ni fendu. Remplacer immédiatement un cordon endommagé. **Un câble dénudé peut tuer.**
- Inspecter et remplacer les câbles de la torche qui sont usés ou endommagés.
- Ne pas saisir la pièce à couper ni les chutes lors du coupage. Laisser la pièce à couper en place ou sur la table de travail, le câble de retour connecté lors du coupage.
- Avant de vérifier, de nettoyer ou de remplacer les pièces de la torche, couper l'alimentation ou débrancher la prise de courant.
- Ne jamais contourner ou court-circuiter les verrouillages de sécurité.
- Avant d'enlever le capot du système ou de la source de courant, couper l'alimentation électrique. Attendre ensuite 5 minutes pour que les condensateurs se déchargent.
- Ne jamais faire fonctionner le système plasma sans que les capots de la source de courant ne soient en place. Les raccords exposés de la source de courant sont extrêmement dangereux.
- Lors de l'installation des connexions, attacher tout d'abord la prise de terre appropriée.
- Chaque système plasma Hypertherm est conçu pour être utilisé uniquement avec des torches Hypertherm spécifiques. Ne pas utiliser des torches inappropriées qui pourraient surchauffer et présenter des risques pour la sécurité.



LE COUPAGE PEUT PRODUIRE DES VAPEURS TOXIQUES

Le coupage peut produire des vapeurs et des gaz toxiques qui réduisent le niveau d'oxygène dans l'air et peuvent provoquer des blessures, voire la mort.

- Conserver le poste de coupage bien aéré ou utiliser un masque respiratoire homologué.
- Ne pas procéder au coupage près d'endroits où s'effectuent le dégraissage, le nettoyage ou la vaporisation. Certains solvants chlorés se décomposent sous l'effet des rayons ultraviolets et forment du phosgène.
- Ne pas couper des métaux peints ou contenant des matières toxiques comme le zinc (galvanisé), le plomb, le cadmium ou le béryllium, à moins que la zone de travail soit très bien ventilée et que l'opérateur porte un masque respiratoire. Les revêtements et métaux contenant ces matières peuvent produire des vapeurs toxiques lors du coupage.
- Ne jamais couper de récipients pouvant contenir des matières inflammables avant de les avoir vidés et nettoyés correctement.



L'ARC PLASMA PEUT PROVOQUER DES BLESSURES OU DES BRÛLURES

Torches à allumage instantané

L'arc plasma s'allume immédiatement après que la torche soit mise en marche.

L'arc plasma coupe facilement les gants et la peau.

- Rester éloigné de l'extrémité de la torche.
- Ne pas tenir de métal près de la trajectoire de coupe.
- Ne jamais pointer la torche vers soi ou d'autres personnes.



LES RAYONS DE L'ARC PEUVENT BRÛLER LES YEUX ET LA PEAU

Protection des yeux Les rayons de l'arc plasma produisent de puissants rayons visibles ou invisibles (ultraviolets et infrarouges) qui peuvent brûler les yeux et la peau.

- Utiliser des lunettes de sécurité conformément aux codes locaux ou nationaux en vigueur.
- Porter des lunettes de protection (lunettes ou masque muni d'écrans latéraux ou encore masque de soudure) avec des verres teintés appropriés pour protéger les yeux des rayons ultraviolets et infrarouges de l'arc.

- Gants à crispin, chaussures et casque de sécurité.
- Vêtements ignifuges couvrant toutes les parties exposées du corps.
- Pantalon sans revers pour éviter que des étincelles ou des scories puissent s'y loger.
- Avant le coupage, retirer de ses poches tout objet combustible comme les briquets au butane ou les allumettes.

Zone de coupage Préparer la zone de coupage afin de réduire la réverbération et la transmission de la lumière ultraviolette :

- Peindre les murs et autres surfaces de couleur sombre pour réduire la réflexion de la lumière.
- Utiliser des écrans et autres dispositifs de protection afin de protéger les autres personnes de la lumière et de la réverbération.
- Prévenir les autres personnes de ne pas regarder l'arc. Utiliser des affiches ou des panneaux.

Courant de l'arc	Puissance des verres teintés	
	AWS (É.-U.)	ISO 4850
Jusqu'à 100 A	N° 8	N° 11
100-200 A	N° 10	N° 11-12
200-400 A	N° 12	N° 13
Plus de 400 A	N° 14	N° 14



Protection de la peau Porter des vêtements de sécurité pour se protéger contre les brûlures que peuvent causer les rayons ultraviolets, les étincelles et le métal brûlant :



MISE À LA MASSE ET À LA TERRE

Câble de retour Bien fixer le câble de retour (ou de masse) à la pièce à couper ou à la table de travail de façon à assurer un bon contact métal-métal. Ne pas fixer le câble de retour à la partie de la pièce qui doit se détacher.

Table de travail Raccorder la table de travail à la terre, conformément aux codes de sécurité locaux ou nationaux appropriés.

Alimentation

- S'assurer que le fil de terre du cordon d'alimentation est connecté à la terre dans le coffret du sectionneur.
- S'il est nécessaire de brancher le cordon d'alimentation à la source de courant lors de l'installation du système, s'assurer que le fil de terre est correctement branché.
- Placer tout d'abord le fil de terre du cordon d'alimentation sur le plot de mise à la terre puis placer les autres fils de terre par-dessus. Bien serrer l'écrou de retenue.
- S'assurer que toutes les connexions sont bien serrées pour éviter la surchauffe.

SÉCURITÉ DES BOUTEILLES DE GAZ COMPRIMÉ

- Ne jamais lubrifier les robinets des bouteilles ou les régulateurs avec de l'huile ou de la graisse.
- Utiliser uniquement les bouteilles, régulateurs, tuyaux et accessoires appropriés et conçus pour chaque application spécifique.
- Entretenir l'équipement et les pièces d'équipement à gaz comprimé afin de les garder en bon état.
- Étiqueter et coder avec des couleurs tous les tuyaux de gaz afin d'identifier le type de gaz contenu dans chaque tuyau. Se référer aux codes locaux ou nationaux en vigueur.



LES BOUTEILLES DE GAZ COMPRIMÉ PEUVENT EXPLOSER EN CAS DE DOMMAGES

Les bouteilles de gaz contiennent du gaz à haute pression. Si une bouteille est endommagée, elle peut exploser.

- Manipuler et utiliser les bouteilles de gaz comprimé conformément aux codes locaux ou nationaux.
- Ne jamais utiliser une bouteille qui n'est pas placée à la verticale et bien assujettie.
- Le capuchon de protection doit être placé sur le robinet sauf si la bouteille est en cours d'utilisation ou connectée pour utilisation.
- Éviter à tout prix le contact électrique entre l'arc plasma et une bouteille.
- Ne jamais exposer des bouteilles à une chaleur excessive, aux étincelles, aux scories ou aux flammes nues.
- Ne jamais utiliser des marteaux, des clés ou d'autres outils pour débloquer le robinet des bouteilles.



LE BRUIT PEUT PROVOQUER DES PROBLÈMES AUDITIFS

Une exposition prolongée au bruit du coupage ou du gougeage peut provoquer des problèmes auditifs.

- Utiliser un casque de protection homologué lors de l'utilisation du système plasma.
- Prévenir les personnes aux alentours des risques encourus en cas d'exposition au bruit.



PACEMAKERS ET PROTHÈSES AUDITIVES

Les champs magnétiques produits par les courants à haute tension peuvent affecter le fonctionnement des prothèses auditives et des pacemakers. Les personnes portant ce type d'appareil doivent consulter un médecin avant de s'approcher d'un lieu où s'effectue le coupage ou le gougeage plasma.

Pour réduire les risques associés aux champs magnétiques :

- Garder loin de soi et du même côté du corps le câble de retour et le faisceau de la torche.
- Faire passer le faisceau de la torche le plus près possible du câble de retour.
- Ne pas s'enrouler le faisceau de la torche ou le câble de retour autour du corps.
- Se tenir le plus loin possible de la source de courant.

Étiquette de sécurité

Cette étiquette est apposée sur certaines sources de courant. Il est important que l'utilisateur et le technicien de maintenance comprennent la signification des symboles de sécurité. Les numéros de la liste correspondent aux numéros des images.



1. Les étincelles produites par le coupage peuvent provoquer une explosion ou un incendie.
 - 1.1 Pendant le coupage, éloigner toute matière inflammable.
 - 1.2 Conserver un extincteur à proximité et s'assurer qu'une personne soit prête à l'utiliser.
 - 1.3 Ne jamais couper de récipients fermés.
2. L'arc plasma peut provoquer des blessures et des brûlures.
 - 2.1 Couper l'alimentation avant de démonter la torche.
 - 2.2 Ne pas tenir la surface à couper près de la trajectoire de coupe.
 - 2.3 Porter des vêtements de protection couvrant tout le corps.
3. Un choc électrique causé par la torche ou les câbles peut être fatal. Se protéger contre les risques de chocs électriques.
 - 3.1 Porter des gants isolants. Ne pas porter de gants mouillés ou abîmés.
 - 3.2 S'isoler de la surface de travail et du sol.
 - 3.3 Débrancher la prise ou la source de courant avant de manipuler l'équipement.
4. L'inhalation des vapeurs produites par le coupage peut être dangereuse pour la santé.
 - 4.1 Garder le visage à l'écart des vapeurs.
 - 4.2 Utiliser un système de ventilation par aspiration ou d'échappement localisé pour dissiper les vapeurs.
 - 4.3 Utiliser un ventilateur pour dissiper les vapeurs.
5. Les rayons de l'arc peuvent brûler les yeux et provoquer des lésions de la peau.
 - 5.1 Porter un casque et des lunettes de sécurité. Se protéger les oreilles et porter une chemise dont le col peut être déboutonné. Porter un casque de soudure dont la protection filtrante est suffisante. Porter des vêtements protecteurs couvrant la totalité du corps.
6. Se former à la technique du coupage et lire les instructions avant de manipuler l'équipement ou de procéder au coupage.
7. Ne pas retirer ou peindre (recouvrir) les étiquettes de sécurité.

Section 2

SPECIFICATIONS

In this section:

SPECIFICATIONS, POWER SUPPLY	2-2
SPECIFICATIONS, PAC123 TORCHES	2-3
SETUP SPECIFICATIONS	2-4
INSTALL POWER CORD PLUG	2-4
CHECK REQUIRED INPUT VOLTAGE	2-4
<input type="checkbox"/> MARK (230/400 VOLT ONLY)	2-4
GROUNDING REQUIREMENTS	2-5
POWER CORD / EXTENSION CORD	2-5
GAS REQUIREMENTS	2-6
LINE VOLTAGE DISCONNECT BOX	2-6

Section 2 SPECIFICATIONS

SPECIFICATIONS, POWER SUPPLY

Rated Open Circuit Voltage (U_0)	300 VDC	
Rated Output Current (I_2)	20A – 40A	
Rated Output Voltage (U_2)	140 VDC	
Duty Cycle at 40° C (See data tag on power supply for more information on duty cycle)	50% ($I_2=40A$, $U_2=140V$)	
	100% ($I_2=28A$, $U_2=140V$)	
Operating temperature	-10° to +40° C (+14° to 104° F)	
Apparent Input Power (S_1)	230/400V = 6.7 kVA 208-240/480V = 9.5 kVA	
Input Voltage (U_1)/Input Current (I_1) at 5.6 kw Output	230V/17A - 3 phase, 50/60 Hz CE 400V/9.7A - 3 phase, 50/60 Hz CE 208-240V/46-40A - 1 phase, 50/60 Hz CSA/NRTL 480V/12A - 3 phase, 50/60 Hz CSA/NRTL	
Gas Type	Air	Nitrogen
Gas Quality	Clean, dry, oil-free	99.995% pure
Gas Inlet Pressure and Flow	See Setup Specifications	

Powermax600 Power Supply Dimensions and Weight

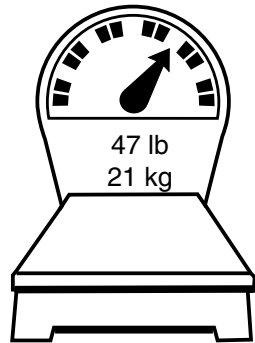

Weight with hand torch and 15 ft / 4.5 m lead.

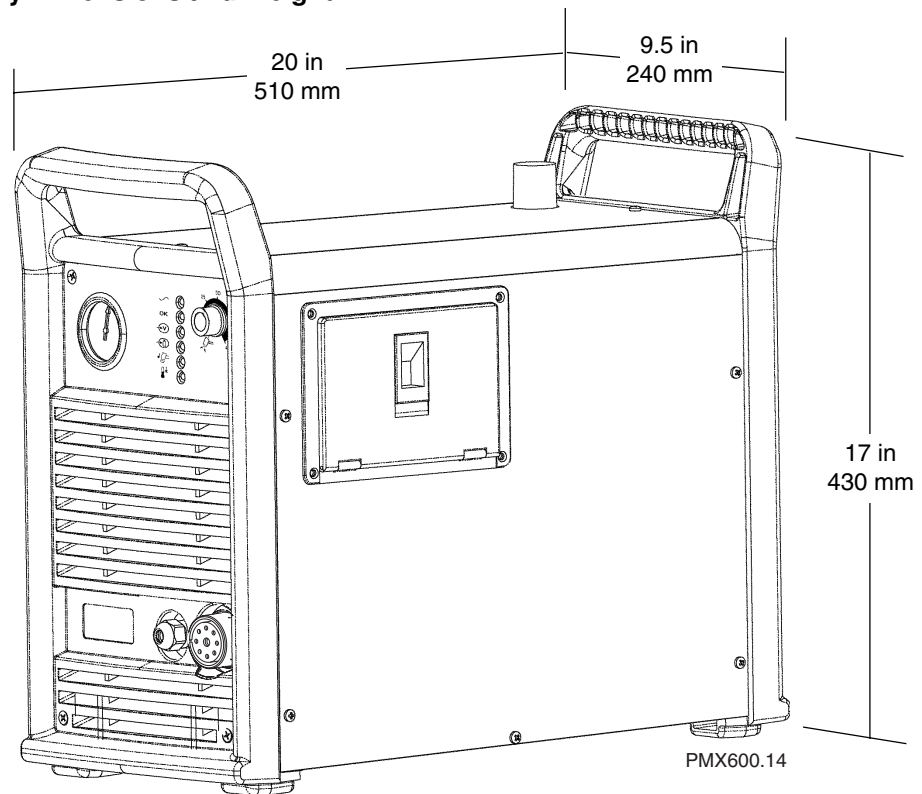
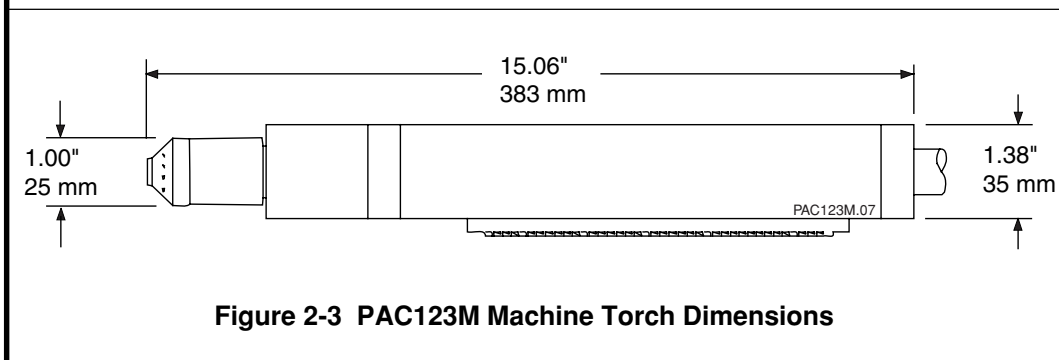
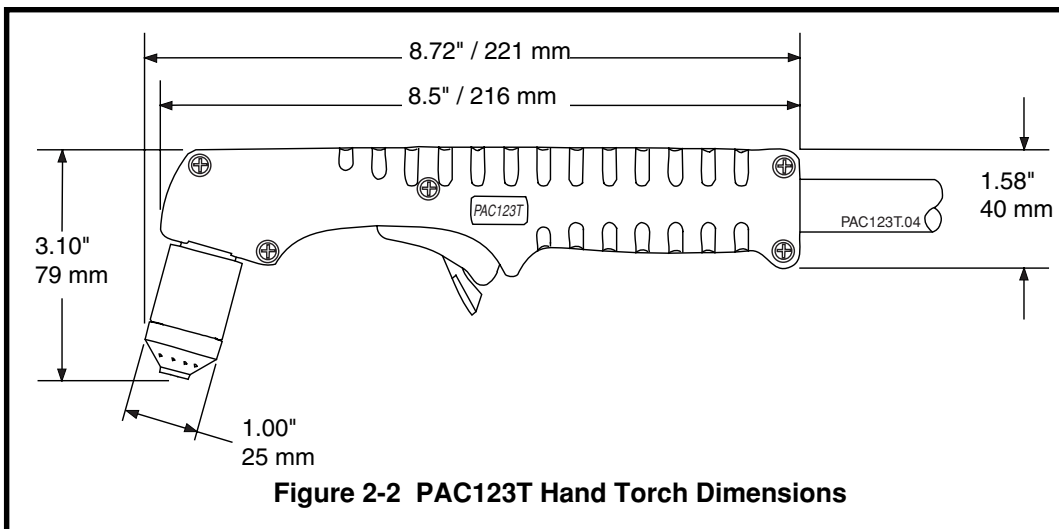

Figure 2-1 Powermax600 Power Supply Dimensions

SPECIFICATIONS, PAC123 TORCHES

Maximum Cutting Capacity	
40A PAC123T	5/8 inch / 16 mm @ 50% duty cycle
40A PAC123M	1/4 inch / 6 mm @ 50% duty cycle
28A PAC123M	1/8 inch / 3 mm @ 100% duty cycle
Gouging Capability (metal removal rate)	
	5.6 pounds / 2.5 kg
Weight	
PAC123T	3.5 pounds / 1.6 kg with 15 ft / 4.5 m lead
	4.5 pounds / 2 kg with 25 ft / 7.5 m lead
	7 pounds / 3.2 kg with 50 ft / 15 m lead
PAC123M	6 pounds / 2.7 kg with 15 ft / 4.5 m lead
	7 pounds / 3.2 kg with 25 ft / 7.5 m lead
	9.5 pounds / 4.3 kg with 50 ft / 15 m lead

Dimensions



SPECIFICATIONS

S MARK (230/400 VOLT ONLY)

The **S** mark indicates that the power supply and torch are suitable for use in environments with increased hazard of electrical shock. The hand torches must have shielded consumable parts to maintain **S** mark compliance.

SETUP SPECIFICATIONS

Check Required Input Voltage

Look at U1 on the data plate to check input voltage requirements. The data plate is on the back of the power supply. See Figure 2-4.

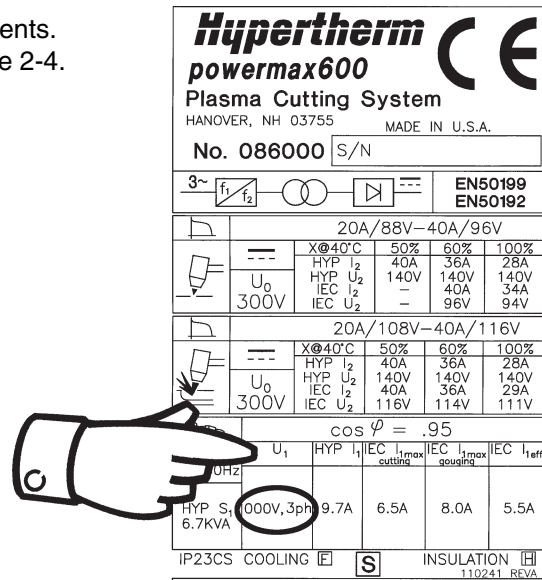
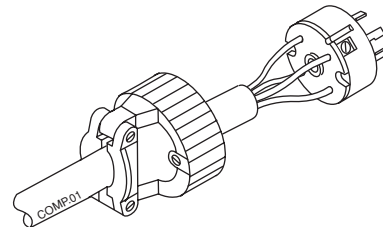

Figure 2-4 Data Plate Input Voltage

Install Power Cord Plug

Use a power cord plug that is certified by national or local electrical codes. The plug should be connected to the power cord by a licensed electrician.



Power Cord / Extension Cord

Use a cord that is certified by national or local codes. The cord should be installed by a licensed electrician. Refer to the length requirements listed below.

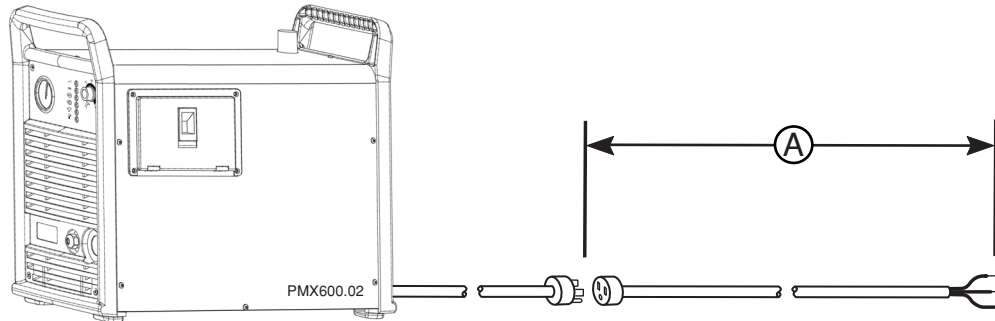

		A				
		< 10 ft < 3 m	10-25 ft 3 – 7.5 m	25-50 ft 7.5 – 15 m	50-100 ft 15 – 30 m	100-150 ft 30 – 45 m
Input Voltage	Phase	Recommended Cord Gauge Size (mm²)				
208-240 VAC	1	10	10	10	16	16
230 VAC	3	4	6	6	10	10
400 VAC	3	2.5	2.5	4	6	6
480 VAC	3	4	4	4	4	6
		Recommended Cord Gauge Size (AWG)				
208-240 VAC	1	8	8	8	6	6
230 VAC	3	12	10	10	8	8
400 VAC	3	14	14	12	10	10
480 VAC	3	12	12	12	12	10

Grounding Requirements

To ensure personal safety, proper operation and to reduce electromagnetic interference (EMI), the Powermax600 must be properly grounded:

- The power supply chassis is electrically conductive and can present a shock hazard if it is not properly grounded through the line voltage disconnect box.
- The power supply must be properly grounded through the power cord according to national or local electrical codes.
- Three-phase service must use a 4-wire cord that includes a protective earth ground.
- Also see *Grounding Safety*, in Section 1 of this manual.

SPECIFICATIONS

Line Voltage Disconnect Box

Use a line disconnect box for each power supply so that the operator can turn the power supply off quickly in an emergency situation. Locate the switch near the power supply so that it is easily accessible to the operator. The interrupt level of the switch must be equal to or exceed the continuous rating of the fuses. Use slow-blow fuses as listed below.

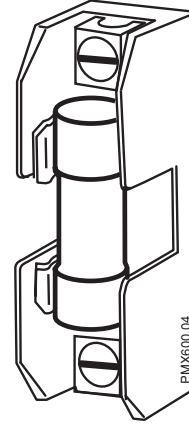
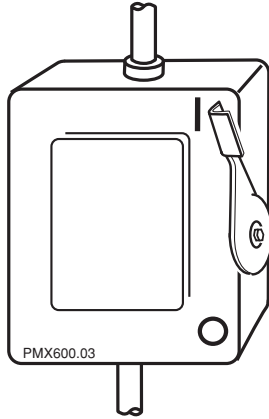

Input Voltage	Phase	Input Current @ 5.6 kw Output	Recommended Slow-Blow Fuse Size
208-240 VAC	1	46-40A	100A
230 VAC	3	17A	40A
400 VAC	3	9.7A	25A
480 VAC	3	12A	25A

Gas Requirements

Air must be filtered to remove all dirt, water and oil. Contaminants can damage the power supply, torch and consummables.

The power supply will not power-up if the gas inlet pressure is below minimum.

CAUTION: Do not exceed 120 psi / 8.3 bar pressure at the power supply gas inlet. Damage to system may result from higher pressures.

Minimum Gas Inlet Pressure	90 psi / 6.2 bar
Gas Flow	6 scfm @ 90 psi / 170 l/min @ 6.2 bar

Section 3

MAINTENANCE





In this section:

CONTROLS AND INDICATORS	3-2
INDICATOR LAMPS	3-2
CONTROLS.	3-2
THEORY OF OPERATION	3-3
GENERAL	3-3
230/400 VOLT FUNCTIONAL DESCRIPTION	3-4
208-240/480 VOLT FUNCTIONAL DESCRIPTION	3-6
SEQUENCE OF OPERATION	3-8
TROUBLESHOOTING	3-9
TEST EQUIPMENT	3-9
TROUBLESHOOTING PROCEDURES AND SEQUENCE	3-9
VISUAL INSPECTION - EXTERNAL	3-9
VISUAL INSPECTION - INTERNAL	3-10
RESISTANCE CHECKS	3-11
TROUBLESHOOTING GUIDE	3-14
VOLTAGE CHECKS	3-21
COMPONENT REPLACEMENT	3-26
POWER CORD REPLACEMENT	3-26
TORCH LEAD REPLACEMENT (MODELS WITHOUT QUICK DISCONNECT)	3-27
AIR FILTER ELEMENT REPLACEMENT	3-28
WORK CABLE REPLACEMENT	3-30
CAPACITOR REPLACEMENT	3-31

MAINTENANCE

CONTROLS AND INDICATORS

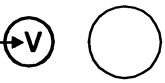
Indicator Lamps

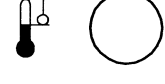
-  **Green POWER IS ON**
When illuminated, indicates that AC voltage is supplied to the power supply and that the ON/OFF switch is in the ON position.
-  **Green SYSTEM READY**
When illuminated, indicates that circuits are activated and that all fault conditions are clear (none of the yellow lamps are illuminated).
-  **Yellow LOW LINE VOLTAGE**
When illuminated, indicates that the AC line voltage is: 1) below operating limits, or 2) is missing 1 phase (230V and 400V systems only).
-  **Yellow LOW GAS PRESSURE**
When illuminated, indicates that the incoming gas pressure is below operating limits.
-  **Yellow TORCH PARTS ARE LOOSE OR REMOVED**
When illuminated, indicates that the torch consumables are loose or not installed.
-  **Yellow HIGH TEMPERATURE**
When illuminated, indicates that the power supply temperature has exceeded operating limits.

Controls - See Figure 3-1.

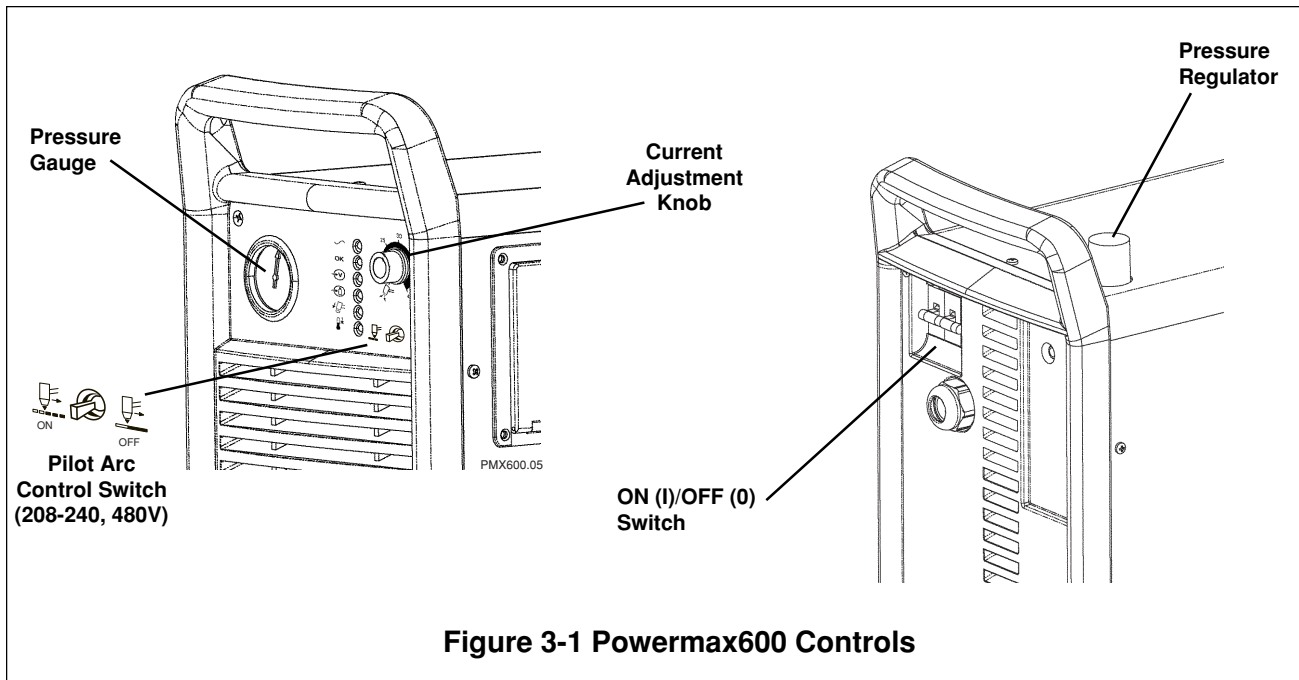

Figure 3-1 Powermax600 Controls

THEORY OF OPERATION

General

Refer to Functional Description, Figures 3-2.1 and 3-2.2, Sequence of Operation and the system wiring diagram.

230/400 Volt Functional Description

See Figure 3-2.1.

Three phase AC power enters the system through the power switch S1 and supplies the EMI filter board PCB1. The filter board provides noise suppression and spike protection. The DC voltage output from the diode bridge D1 supplies the inverter and supplies the flyback system power supply (DC to DC converter) on the power board PCB2. A “soft start” is implemented via power board resistor RT5 and relay K1.

The inverter consists of several components: an isolated gate bipolar transistor (IGBT Q2), the power transformer (T2), a current sense transformer (LEM), power factor choke and sections of the power board. The inverter operates as a pulse width modulator controlled bridge circuit and is rectified by the output diode D2.

The output circuitry consists of 2 current transfer sensors located on the power board, the pilot arc IGBT Q3 and the output choke L2.

The control board microprocessor monitors and regulates system operation and safety circuits. The current is set to the desired value by adjusting the current adjust potentiometer. The system compares the set point to the output current by monitoring the current sensor and adjusting the pulse width output of the inverter IGBT Q2.

Designator	Component
D1	Input diode bridge
D2	Output diode
L1	Input choke inductor
L2	Output choke inductor
M1	Fan
PCB1	Filter board
PCB2	Power board
PCB3	Control board
PS1	Pressure switch
Q2	IGBT module
Q3	Pilot arc IGBT
S1	Breaker
TB1	Terminal block
TS1	Heatsink temperature sensor
TS2	Transformer temperature sensor
T2	Power transformer
V1	Solenoid valve

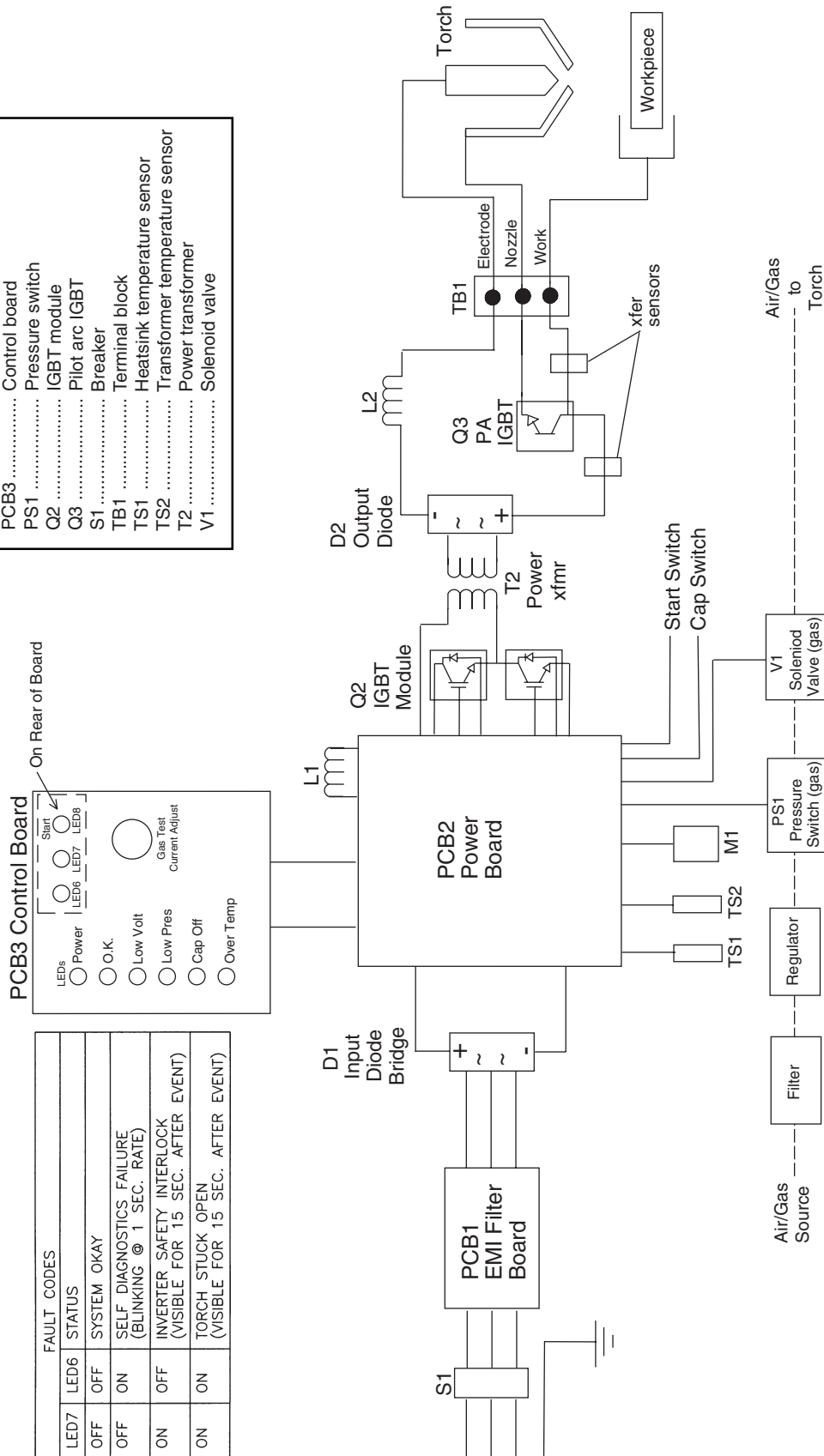

Figure 3-2.1 Powermax600 230/400 Volt Block Diagram

208-240/480 Volt Functional Description

See Figure 3-2.2.

AC power enters the system through the power switch S1 to the input diode bridge D18. The DC voltage output from the diode bridge D1 supplies the inverter and supplies the flyback system power supply (DC to DC converter) on the power board PCB2. The power board provides noise suppression and spike protection. A “soft start” is implemented via power board resistor RT5 and relay K1.

The inverter consists of several components: an isolated gate bipolar transistor (IGBT Q2), the power transformer (T2), a current sense transformer (LEM), power factor choke and sections of the power board. The inverter operates as a pulse width modulator controlled bridge circuit and is rectified by the output diode D2.

The output circuitry consists of 2 current transfer sensors located on the power board, the pilot arc IGBT Q3 and the output choke L2.

The control board microprocessor monitors and regulates system operation and safety circuits. The current is set to the desired value by adjusting the current adjust potentiometer. The system compares the set point to the output current by monitoring the current sensor and adjusting the pulse width output of the inverter IGBT Q2.

The control board PCB3 includes a pilot arc control switch, allowing the operator to turn the pilot arc ON (useful when cutting expanded metal) or OFF for maximum consumable life.

Designator	Component
D18	Input diode bridge
D2	Output diode
L2	Output choke inductor
M1	Fan
PCB2	Power board
PCB3	Control board
PS1	Pressure switch
Q2	IGBT module
Q3	Pilot arc IGBT
S1	Breaker
TB1	Terminal block
TS1	Heatsink temperature sensor
TS2	Transformer temperature sensor
T2	Power transformer
V1	Solenoid valve

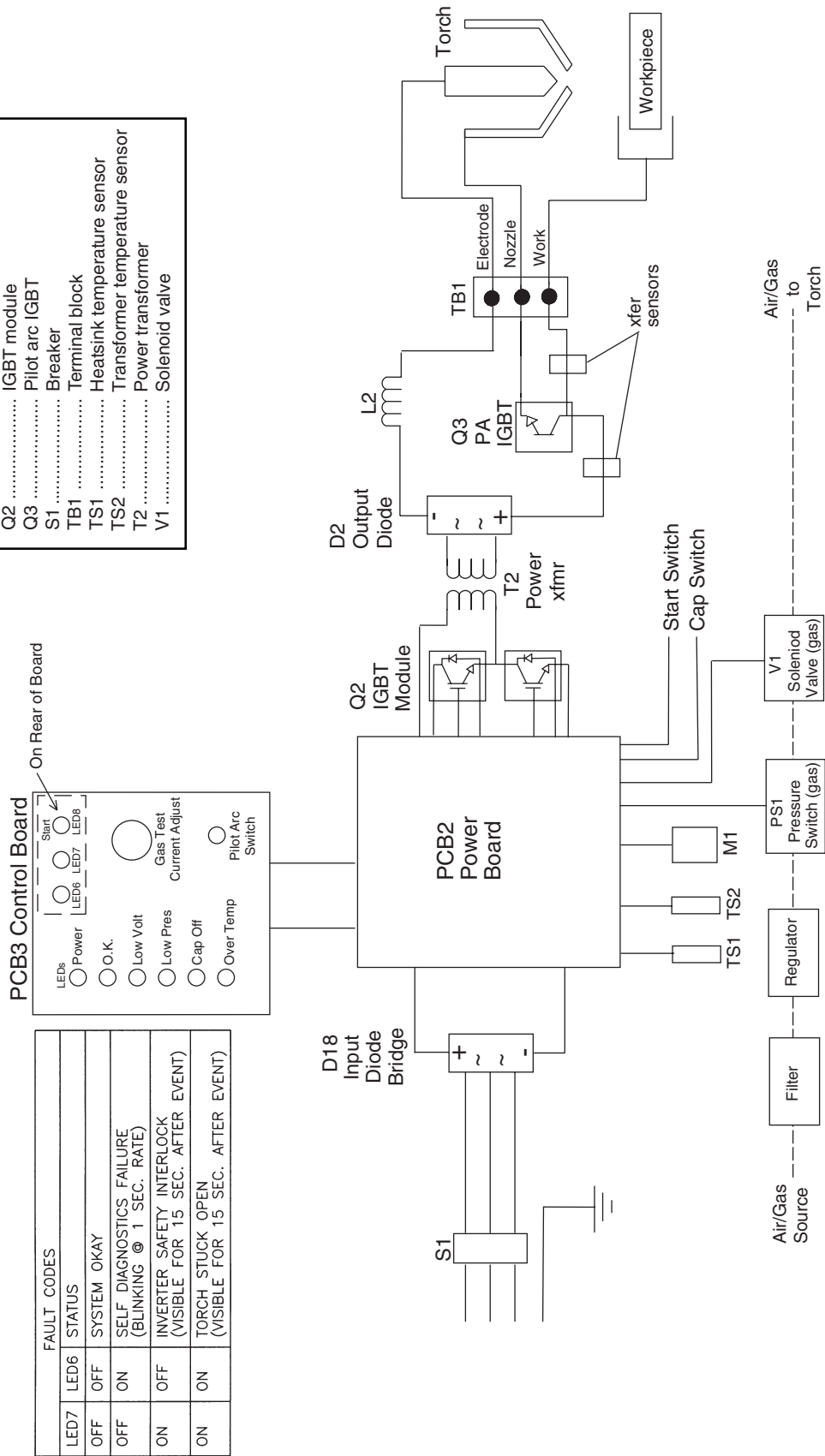

FAULT CODES	
LED7	LED6
OFF	OFF
OFF	ON
ON	OFF
ON	ON

STATUS	SYSTEM OKAY
SELF DIAGNOSTICS FAILURE (BLINKING @ 1 SEC. RATE)	INVERTER SAFETY INTERLOCK (VISIBLE FOR 15 SEC. AFTER EVENT)
TORCH STUCK OPEN (VISIBLE FOR 15 SEC. AFTER EVENT)	

Figure 3-2.2 Powermax600 208-240/480 Volt Block Diagram

MAINTENANCE

Sequence of Operation

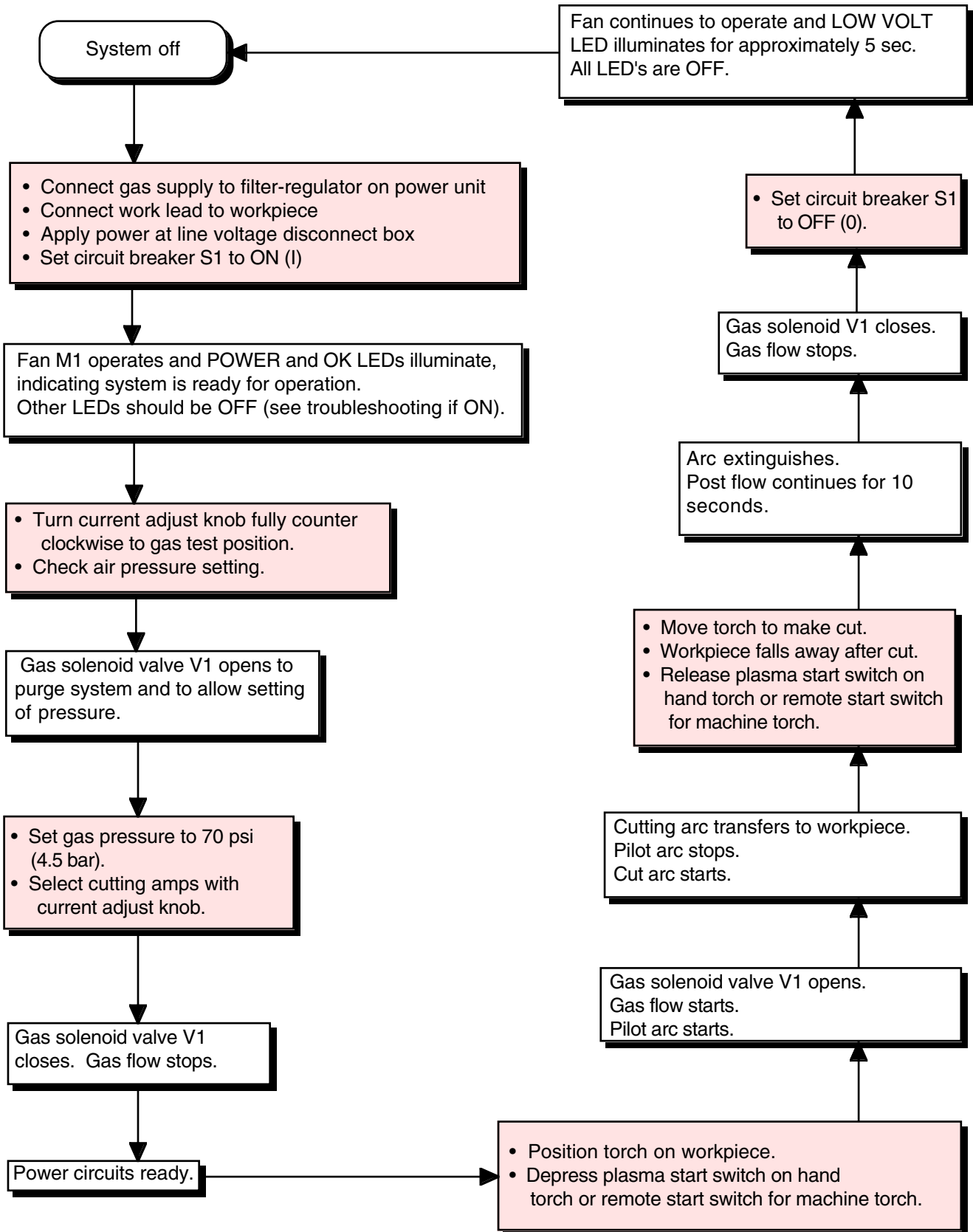

TROUBLESHOOTING

The complexity of the circuits require that service technicians have a working knowledge of inverter power supply theory. In addition to being technically qualified, technicians must perform all testing with safety in mind.

If questions or problems arise during servicing, call the Hypertherm Technical Services Department at the phone numbers listed in the front of this manual.

Test Equipment

- Multimeter



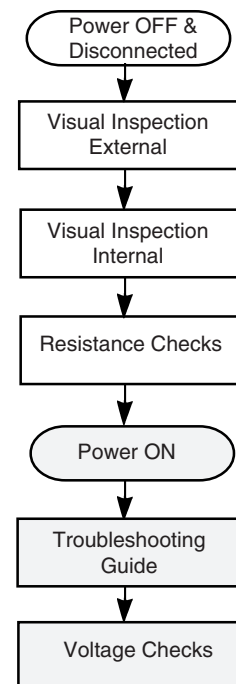

Troubleshooting Procedures and Sequence

- Refer to the system wiring diagram when performing the troubleshooting procedures.
- To locate power supply components refer to Section 4. Refer to Section 5 for torch components.
- After the problem has been located and repaired, refer to the *Sequence of Operation* flow diagram in this section to test the power supply for proper operation.



Visual Inspection - External

1. Inspect the outside of the power supply for damage to the cover and external components.
2. Inspect the torch and the torch lead for damage.

 WARNING	
	ELECTRIC SHOCK CAN KILL <ul style="list-style-type: none">• Turn off the power and remove the input power plug from its receptacle before removing the cover from the power supply. If the power supply is directly connected to a line disconnect box, switch the line disconnect to OFF (O). In the U.S., use a "lock-out / tag-out" procedure until the service or maintenance work is complete. In other countries, follow appropriate national or local safety procedures.• Do not touch live electrical parts! If power is required for servicing, use extreme caution when working near live electrical circuits. Dangerous voltages exist inside the power supply that can cause serious injury or death.• Do not attempt to repair the power board or control board. Do not cut away or remove any protective conformal coating from either board. To do so will risk a short circuit between the AC input circuit and the output circuit and may result serious injury or death.
	HOT PARTS CAN CAUSE SEVERE BURNS <ul style="list-style-type: none">• Allow the power supply to cool before servicing.
	MOVING FAN CAN CAUSE INJURY <ul style="list-style-type: none">• Keep hands away from moving parts.
	STATIC ELECTRICITY CAN DAMAGE CIRCUIT BOARDS <ul style="list-style-type: none">• Put on a grounded wrist strap BEFORE handling PC boards.

Visual Inspection - Internal

1. Set the power switch to O (off), unplug the power cord, and disconnect the gas supply.
2. Remove the cover of the power supply by removing the securing screws.
3. Inspect the inside of the power supply, especially on the side with the power board. Look for broken or loose wiring connections, burn and char marks, damaged components, etc. Repair or replace as necessary.

Resistance Checks

All resistance values were taken with the power cord disconnected and all internal power supply wires attached. Perform Visual Inspection - Internal before continuing in this section.

- If your resistance values are not close to the values given in this section, isolate the problem by removing wires attached to the resistance check points or component until the problem is found.
- After the problem has been located and repaired, refer to the Sequence of Operation flow diagram in this section to test the power unit for proper operation.

Resistance Check #1 - Figure 3-3

1. Turn switch ON (power disconnected).
2. Check resistance across input leads.
3. Check resistance from input leads to ground.

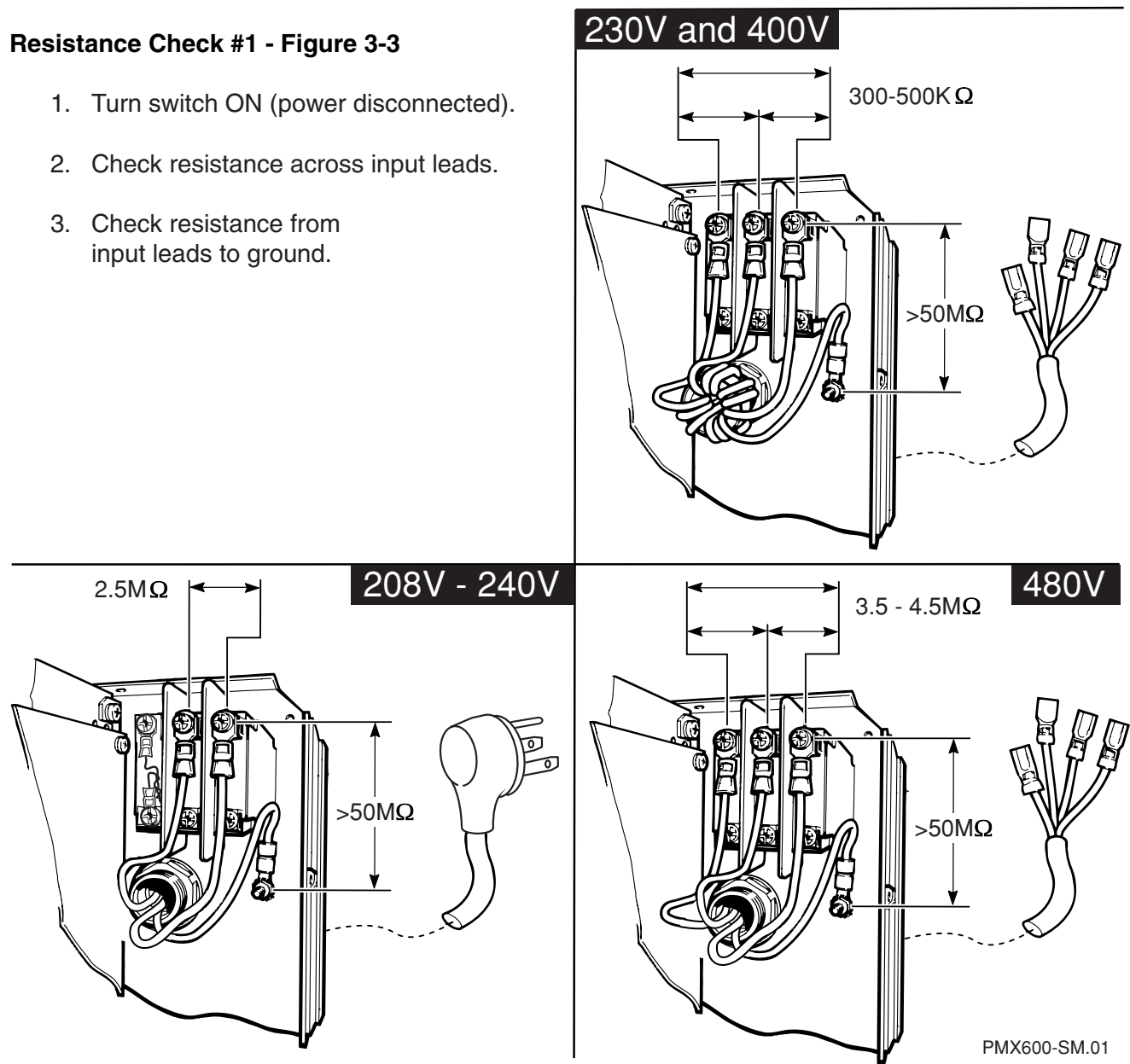

Figure 3-3 Resistance Check #1 - Across Input Leads and Input to Ground

MAINTENANCE

Resistance Check #2 - Figure 3-4

- Check resistance from power board connection to chassis.

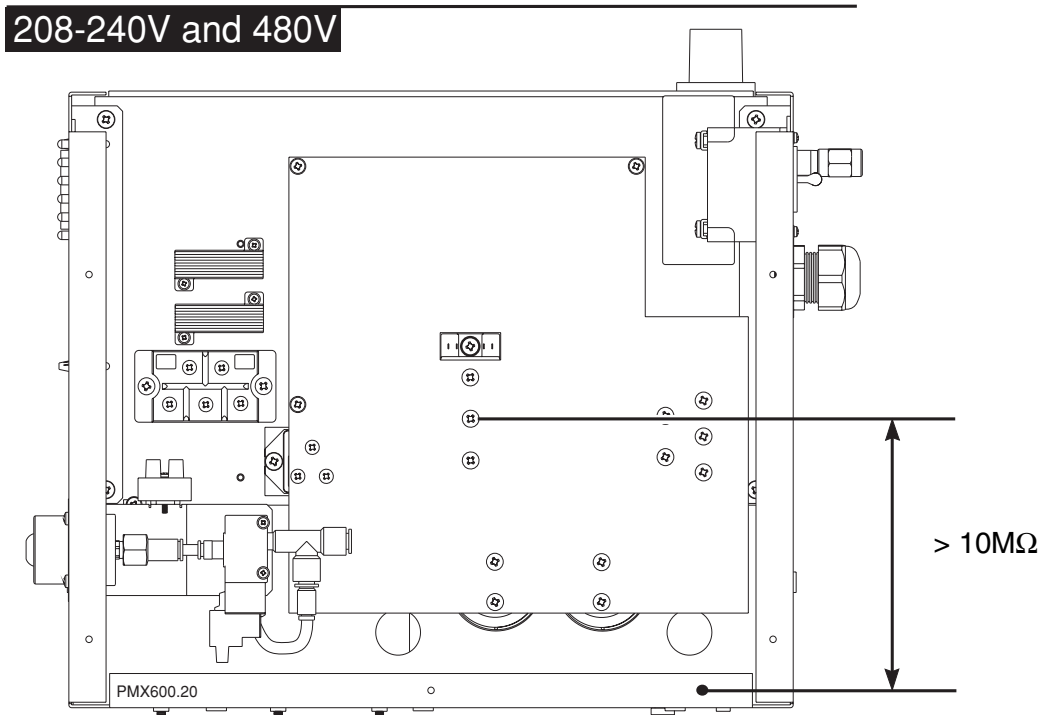
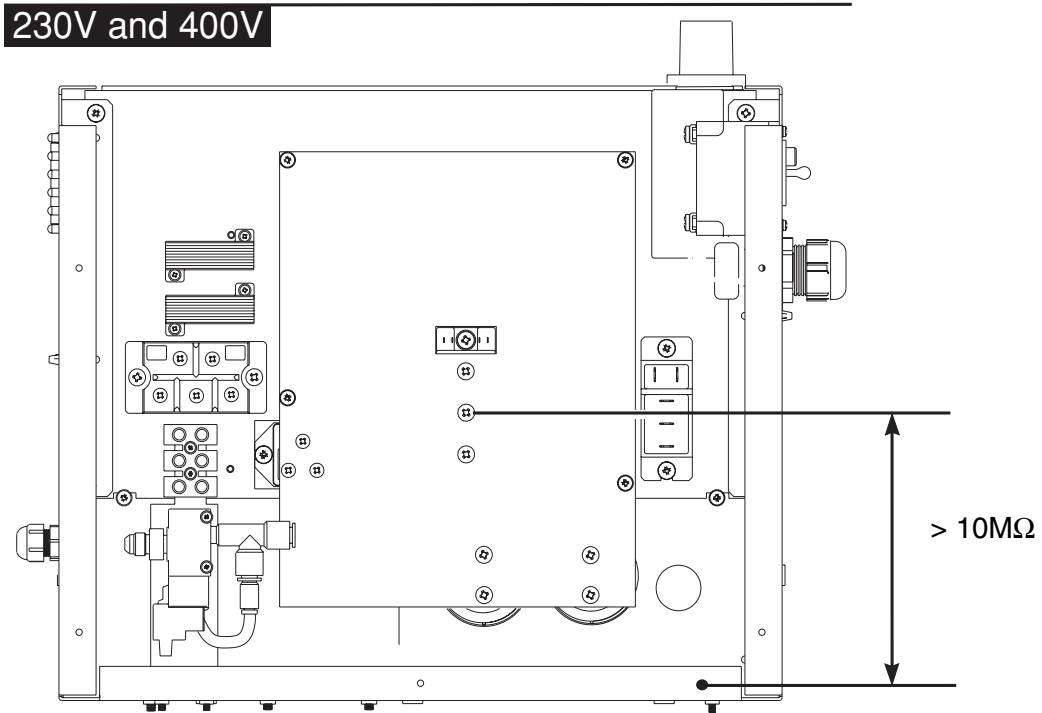

Figure 3-4 Resistance Check #2 - Power Board to Chassis

Resistance Check #3 - Figure 3-5

- Check resistance across output diode bridge.

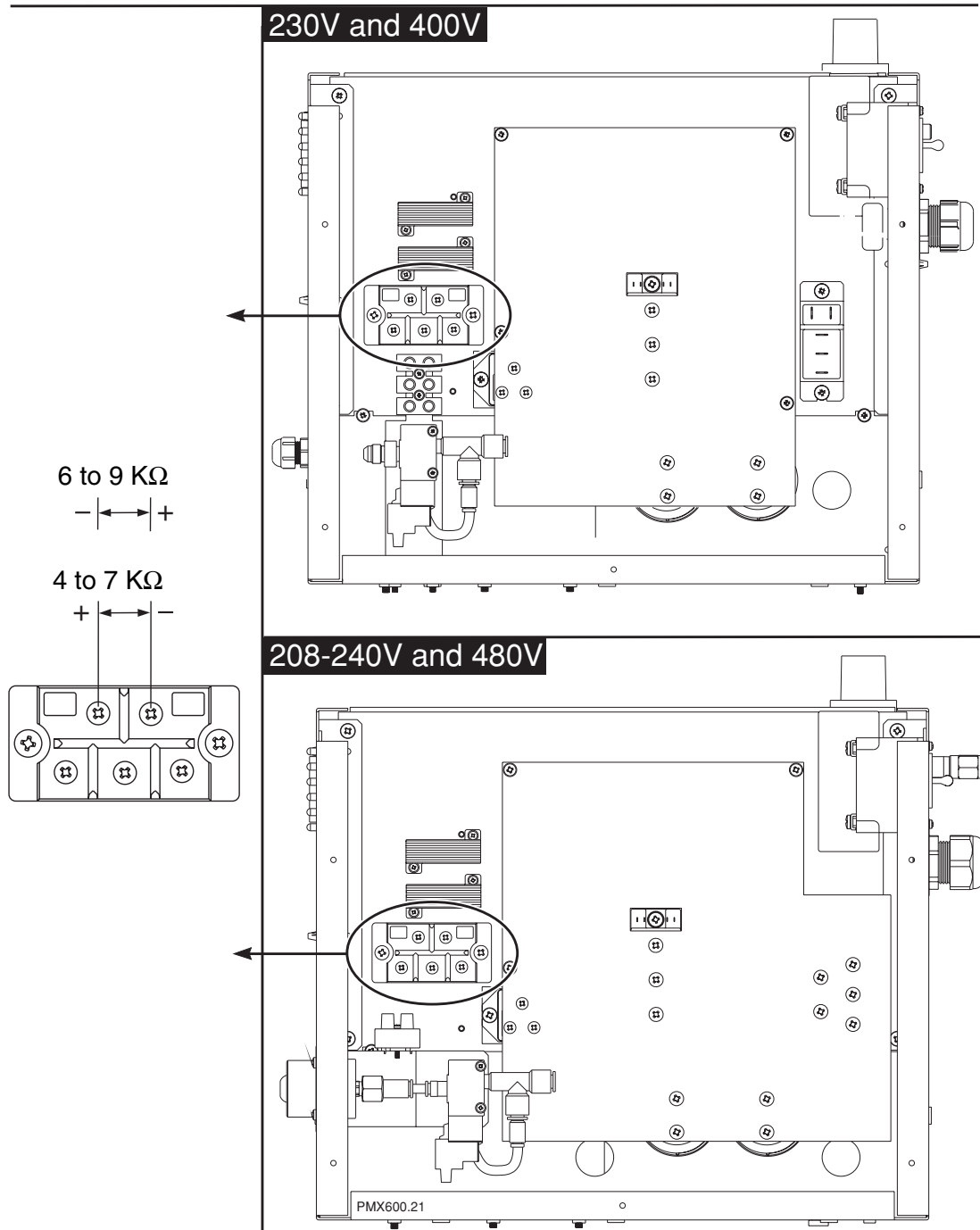



Figure 3-5 Resistance Check #3 - Output Diode Bridge

Troubleshooting Guide





	<h1>WARNING</h1>
	<p>ELECTRIC SHOCK CAN KILL</p> <ul style="list-style-type: none">• Use extreme caution when working near live electrical circuits. Dangerous voltages exist inside the power supply that can cause serious injury or death.• See warnings on page 3-6 before proceeding.





If no problems were found during the initial resistance checks and the power supply still does not operate correctly, follow the *Troubleshooting Guide*.

Note: The *Troubleshooting Guide* provides most probable cause and solutions. Study the system wiring diagram and understand the theory of operation before troubleshooting. Before purchasing a major replacement component, verify the problem with Hypertherm Technical Service or the nearest Hypertherm repair facility.

Problem	This May Mean	Cause	Solution
<p>1. Turn circuit breaker on and no status LED's illuminate</p>	<p>Insufficient voltage to control circuits or shorted power component</p>	<p>No or improper voltage applied to unit</p> <p>Defective breaker (S1)</p> <p>230V & 400V System only: Defective filter board (PCB1)</p> <p>230V & 400V System only: Defective input diode bridge (D1), power board (PCB2) or IGBT module (Q2).</p> <p>208-240V & 480V System only: Defective input diode bridge (D18), power board (PCB2) or IGBT module (Q2).</p> <p>Defective power board (PCB2) or control board (PCB3)</p>	<p>1.1 Verify incoming voltage is correct.</p> <p>1.2 Measure AC voltage at bottom terminals of breaker. If no voltage, replace breaker.</p> <p>1.3 230V & 400V System only: Measure AC voltage between wires 8, 9 & 10 from bottom of breaker. If no or low voltage, replace filter board.</p> <p>1.4a 230V & 400V System only: Measure DC voltage between wires 14 & 15 on input diode bridge. Voltage should be 565 VDC on 400 volt units & 325 on 230 volt units. If incorrect or no voltage, remove wire 14 from K1 on power board and repeat voltage check. If incorrect or no voltage, replace input diode bridge. If voltage is correct, inspect power board and IGBT module for damage.</p> <p>1.4b 208-240V & 480V System only: Measure DC voltage on D18 between two left screws with no wires attached. Voltage should be 660 VDC on 480 volt units & 330 on 208-240 volt units. If incorrect or no voltage, replace input diode bridge. If voltage is correct, inspect power board and IGBT module for damage.</p> <p>1.5 Disconnect power board J1 connector and measure for VDC on power board TP1: J1-Pin1 to TP1 = 12 VDC J1-Pin2 to TP1 = 5 VDC If incorrect or no voltage, replace power board. If voltage is correct, replace control board.</p>

MAINTENANCE

Problem	This May Mean	Cause	Solution
2. Circuit breaker trips immediately when power is applied	Over voltage condition Shorted internal components	Improper voltage applied Over current condition	2.1 Verify incoming voltage is correct. 2.2 Replace damaged assembly.
3. Power LED illuminates, but OK LED does not illuminate OK 	Start signal is on	Depressed torch trigger or shorted start signal	3.1 Check LED8 on control board. If LED8 is illuminated, verify trigger is not pressed or torch lead wires/start switch are not shorted. Correct problem and recycle power to reset system.
4. Power LED illuminates and air flows from torch (torch trigger/start switch not pressed)	System is in gas test mode	Current adjust knob is in gas test position	4.1 Turn knob clockwise until above the 20 amp setting.
	Solenoid valve (V1) stuck open	Faulty valve	4.2 Disconnect J15 from power board. If air flow continues, replace valve.
5. Voltage LED illuminates  	Defective power board (PCB2)	Constant voltage supplied to valve	4.3 Disconnect J15 from power board. If air flow stops, replace power board.
	Improper line voltage	Voltage below proper operating limits or loss of phase	5.1 Verify incoming line voltage and linking, if equipped.
6. Air pressure LED illuminates  	Insufficient air pressure	No air supplied to unit	6.1 Connect air supply.
		Air pressure below operating requirements	6.2 70 psi (4.8 bar) is required for system operation. Check that the inlet gas pressure is within setup specifications in section 2.
	Faulty air pressure switch. 39 psi (2.5 bar) is required to activate the pressure switch.		6.3a 230V & 400V System only: If supply pressure is above 39 psi (2.5 bar), check continuity on J14, pins 3 & 4 on power board. If open continuity, replace switch.

Problem	This May Mean	Cause	Solution
			<p>6.3b 208-240V & 480V System only: If supply pressure is above 39 psi (2.5 bar), check continuity on J14, pins 3 & 4 on wires. If open continuity, replace switch.</p> <p>6.4 Replace air filter element.</p>
<p>7. Cap sense LED illuminates  </p>	<p>Safety circuit not satisfied</p>	<p>Dirty air filter element</p> <p>Consumables not installed, installed improperly, or damaged</p> <p>Damage to safety circuit</p>	<p>7.1 Refer to consumable diagram for proper installation. Try new consumables.</p> <p>7.2 Install consumables and check continuity on J2, pins 1 & 2 orange & blue wires on power board. If open circuit, inspect torch & lead assembly.</p>
<p>8. Over temp LED illuminates  </p>	<p>Temp sensors not satisfied</p>	<p>Exceeded duty cycle</p> <p>Fan not operating or improperly operating</p> <p>Defective heatsink temperature switch TS1 (check when system is cool, at least 15 min after use)</p> <p>Defective power transformer (T2) temperature sensor TS2 (check when system is cool, at least 15 min after use)</p>	<p>8.1 Allow unit to cool. Stay with duty cycle limits in manual.</p> <p>8.2 Verify voltage is being supplied to fan. If voltage is present replace fan. If no voltage check J16 pins 1 & 3 on power board. If present check wiring, if not replace power board.</p> <p>8.3 Check temperature switch by checking continuity on J14 pins 1 & 2 on power board. If no continuity, remove wires from temperature switch and check switch for continuity. If open, replace switch. If closed, check wires from switch to J14.</p> <p>8.4 Check transformer sensor by checking resistance on J17 pins 1&2 on wires. If greater than 1.5 k ohms, replace power transformer.</p>

MAINTENANCE



Problem	This May Mean	Cause	Solution	
9. Power LED and OK LED illuminates, all status LED's off, but no air flow or firing of torch when torch trigger is pressed	Start signal not being received by power supply. LED8 off on control board (PCB3).	Damage to torch & lead assembly.	9.1 Check J2, pins 2 & 3 purple & orange wires on power board for continuity when torch trigger is pulled. If open circuit, inspect torch & lead assembly.	
	Solenoid valve not working	Valve stuck or no voltage to valve	9.2 Verify voltage at valve. Remove connector from valve, turn current adjust knob to test flow and check for 24 VDC at connector. If no voltage, replace power board. If voltage, clear air lines or replace valve.	
	Damaged torch or lead assembly	Torch plunger stuck open or broken torch leads	9.3 Verify fault: control board LED 6 & 7 illuminated. Inspect torch & lead assembly.	
	Damaged control board (PCB3)	Defective control board	9.4 Verify fault: control board LED 6 illuminated & blinking. Replace control board.	
	Worn or bad consumables	Overuse or improperly installed consumables	10.1 Replace consumables.	
	Insufficient air flow	Improper pressure setting	10.2 Turn current adjust knob to test flow and set pressure regulator to 70 psi (4.7 bar).	
	No output from power board (PCB2)	Power board failure, or damaged torch or lead assembly.	10.3 Verify fault: control board inverter fault LED7 illuminated. If LED7 is illuminated, replace power board. If LED7 is NOT illuminated, replace torch & lead assembly. NOTE: OCV is 300VDC but is only available for 100 msec.	
	10. When pressing torch trigger/start switch, air flows from torch, but no arc			

Problem	This May Mean	Cause	Solution
11. When pressing torch trigger/start switch, pilot arc starts but goes out within 5 seconds	Worn consumables	Overuse of consumables	11.1 Replace consumables
	Improper air pressure setting or low flow	Insufficient supply or air leak on supply line	11.2 Turn current adjust knob to test flow and set pressure regulator to 70 psi (4.7 bar). If can not adjust to 70 psi (4.7 bar), check external air supply.
	Poor quality air	Moisture or contaminates in air line	11.3 Add appropriate filtration and purge lines with Nitrogen.
	Insufficient input power	Undersized electrical supply installation: - Breaker/fuse - Supply wire - Extension cord	11.4 Verify external electrical power is installed per specifications in section 2. Check input voltage while trying to fire torch. Voltage drop indicates undersized electrical supply installation.
	Inverter fault or interlock	Power board (PCB2) failure	11.5 If the control board inverter fault LED7 illuminates and one or more of the status LED's illuminate, then the fault is caused by the parameter monitored by the status LED. If no status LED is illuminated, replace power board.

MAINTENANCE

Problem	This May Mean	Cause	Solution
12. Machine will not cut material (does not appear to be operating at full cutting power)	Inadequate ground	Poor work lead connection	12.1 Verify work lead is attached to workpiece and workpiece is free of rust, paint, etc.
		Damaged work lead	12.2 Check continuity of work lead. Replace or repair as required.
		Defective pilot arc IGBT (Q3)	12.3 Turn power off, remove consumables, check resistance between plunger and workpiece. If resistance is greater than 5 k ohms: a) Inspect work lead. b) Check pilot arc IGBT resistance between E & C on power board. If resistance is less than 5 k ohms, replace pilot arc IGBT.
13. 208-240V & 480V System only: Loosing arc transfer when going off plate.	Low power supply output Unit is going into pilot arc controller mode Continuous pilot arc does not work.	Current adjustment set too low	11.1 Verify current adjust knob is at proper setting (turn to max, full clockwise).
		Defective power board current sensor	11.2 Replace power board. Can confirm power output by measuring with a DC current clamp meter on work lead.
		Incorrect torch standoff or exceeding system capability	11.3 Reduce torch standoff or metal is too thick.
13. 208-240V & 480V System only: Loosing arc transfer when going off plate.	Continuous pilot arc does not work.	Incorrect operation	12.1 Pilot control switch not in correct position.
		Faulty control board PCB3	12.2 Replace control board.

Voltage Checks

	<h1>WARNING</h1>
	<p>ELECTRIC SHOCK CAN KILL</p> <ul style="list-style-type: none">• Use extreme caution when working near live electrical circuits. Dangerous voltages exist inside the power supply that can cause serious injury or death.• See warnings on page 3-6 before proceeding.

Before performing voltage checks, complete *Visual Inspection - Internal, Resistance Checks* and the troubleshooting guide.

- Connect the power cord into the line voltage disconnect switch box or plug into a properly grounded outlet.
- Connect the gas supply to the power supply.
- Switch the power supply on.

MAINTENANCE

Voltage Check #1 - Figure 3-5

- Check input voltage to the input diode bridge.
The AC voltage between any 2 input wires should equal the line voltage.

230V and 400V

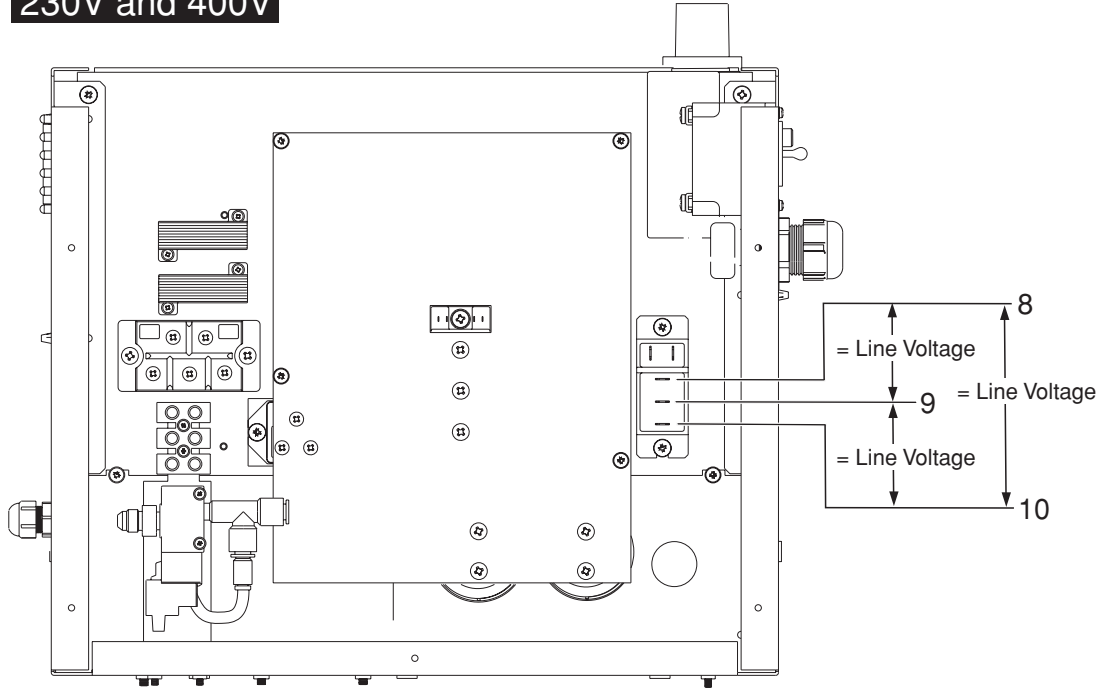

208-240V and 480V

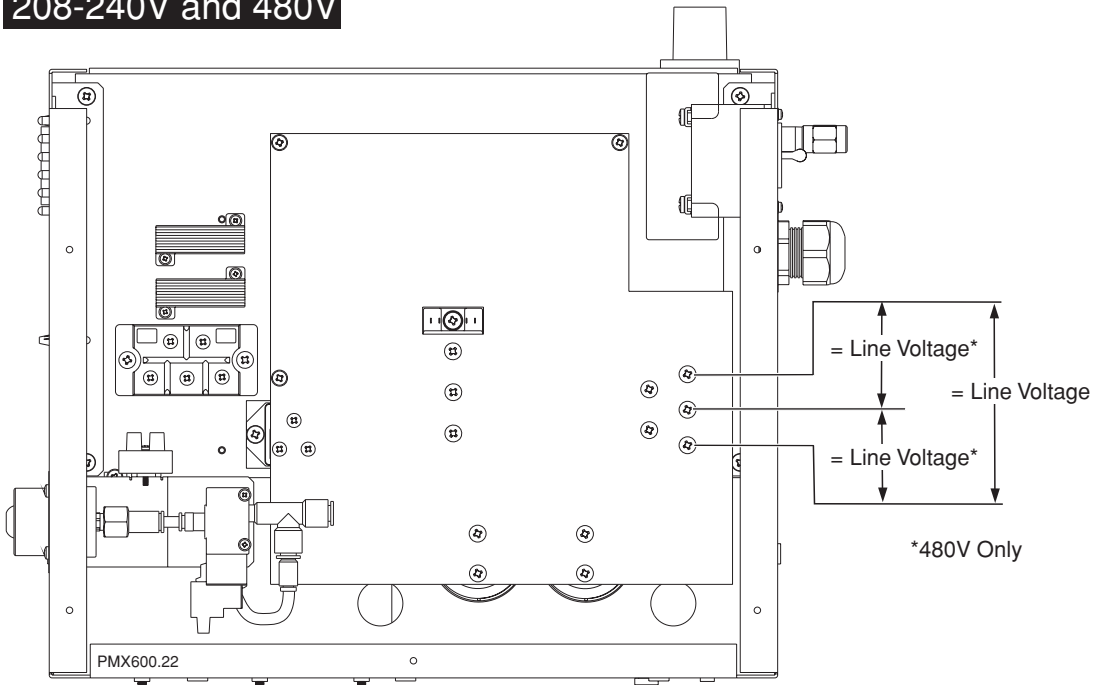

Figure 3-5 Voltage Check #1 - Input of Input Diode Bridge

Voltage Check #2 - Figure 3-6

- Check output voltage of the input diode bridge.

Line Voltage	Output at Bridge
230 VAC	≈ 325 VDC
400 VAC	≈ 565 VDC
208-240 VAC	≈ 300-330 VDC
480 VAC	≈ 660 VDC

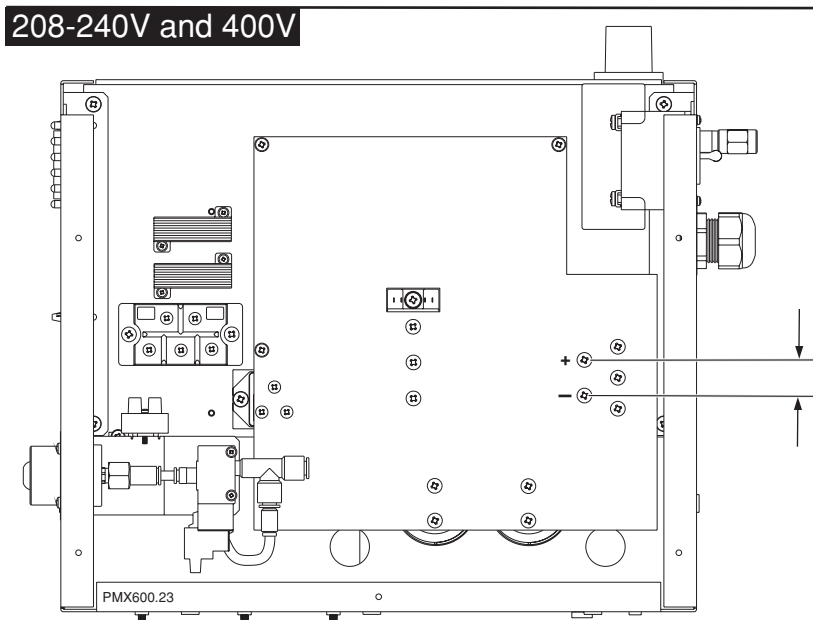
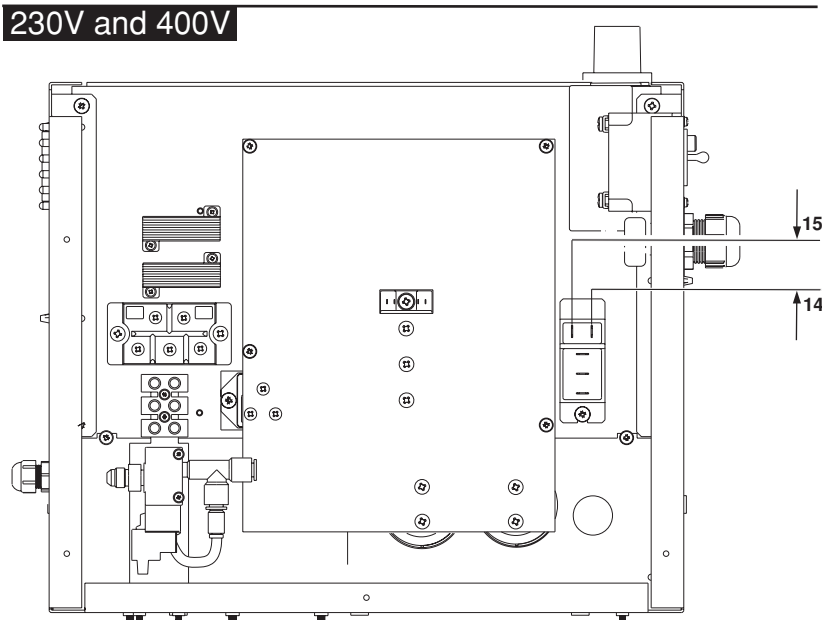

Figure 3-6 Voltage Check #2 - Output of Input Diode Bridge

MAINTENANCE

Voltage Check #3 - Figure 3-7

- Check voltage across IGBT module.

Line Voltage	VDC Across Connections		
	A	B	C
230 VAC	≈ 160	≈ 160	≈ 325
400 VAC	≈ 280	≈ 280	≈ 565
208-240 VAC	≈ 165	≈ 165	≈ 330
480 VAC	≈ 330	≈ 330	≈ 660

230V and 400V

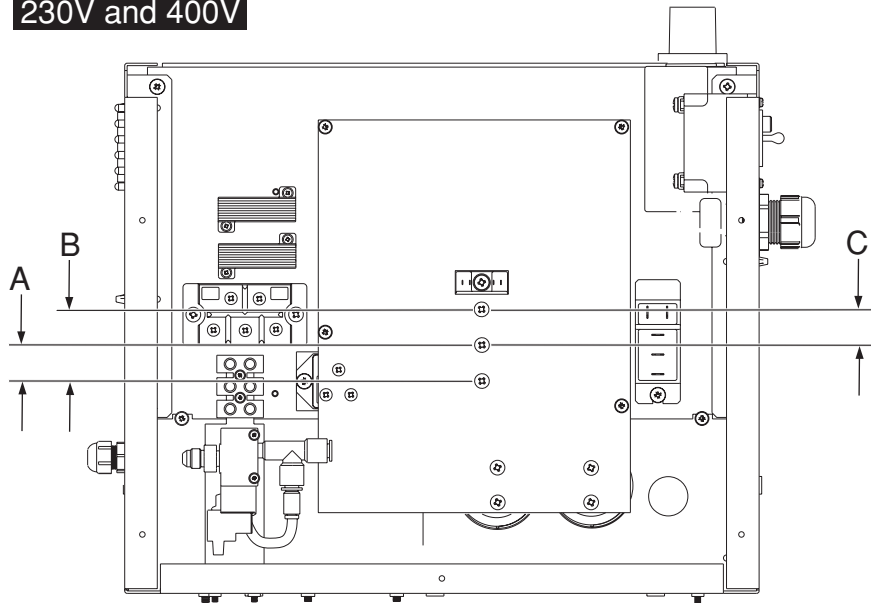

208-240V and 480V

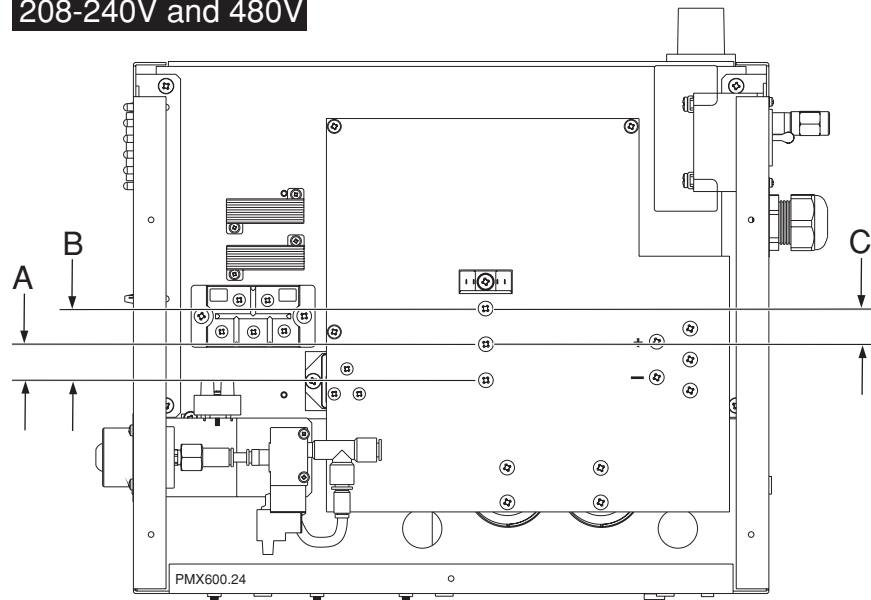

Figure 3-7 Voltage Check #3 - Across IGBT Module

Voltage Check #4 - Figure 3-8

- Check voltage across power supply capacitors.

Line Voltage	VDC Across Connections
230 VAC	≈ 290 VDC
400 VAC	≈ 290 VDC
208-240 VAC	≈ 165-165 VDC
480 VAC	≈ 330 VDC

230V and 400V

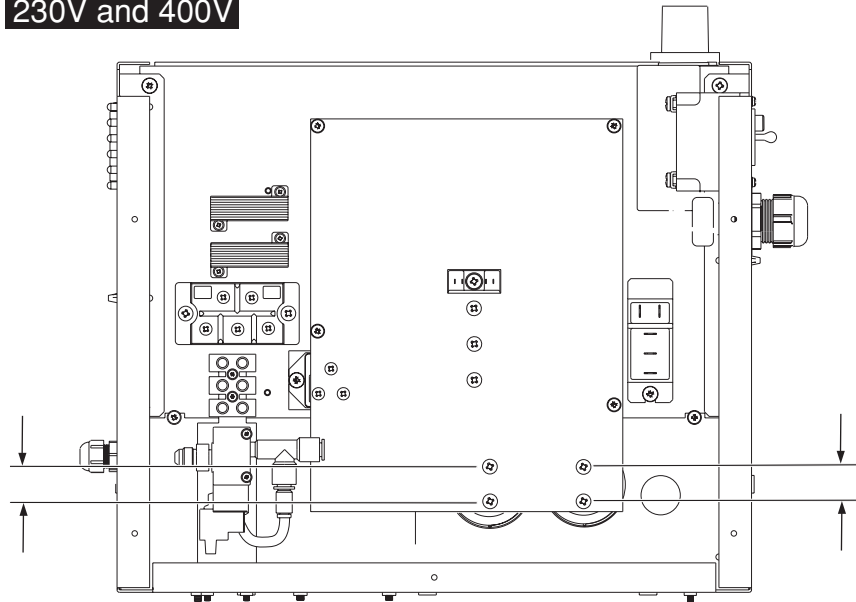

208-240V and 480V

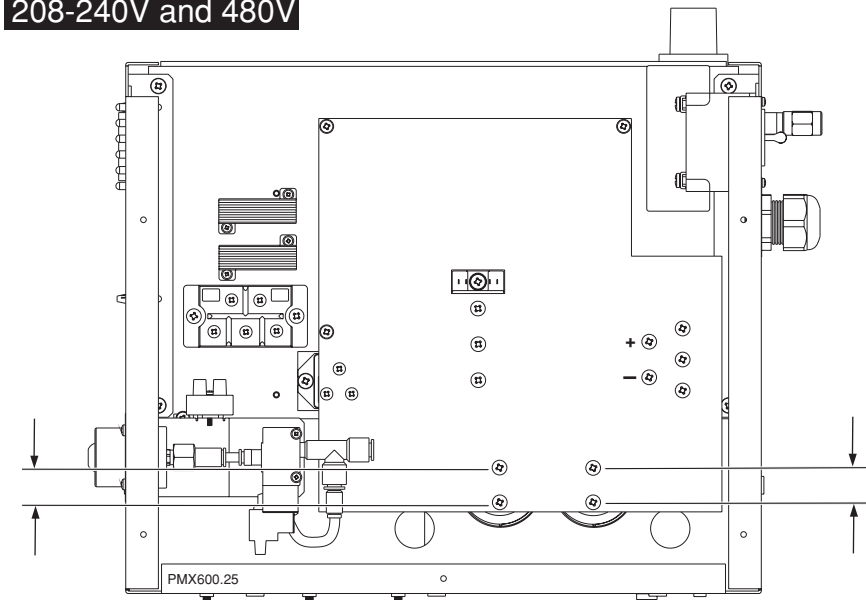



Figure 3-8 Voltage Check #4 - Across Power Supply Capacitors

MAINTENANCE

COMPONENT REPLACEMENT

	<h1>WARNING</h1>
	<p>ELECTRIC SHOCK CAN KILL</p> <ul style="list-style-type: none">• Disconnect electrical power before performing any maintenance.• See warnings on page 3-6 before proceeding.

Power Cord Replacement

Disconnect electrical power and gas supply before removing the old power cord.

Installation - See Figure 3-10.

1. Insert the new power cord through the strain relief.
2. Pass all 4 wires through the toroid, as shown (230 and 400 volt only).
3. Install the power cord connections where shown.
4. Tighten the strain relief onto the power cord.
5. Install the power supply cover.
6. Reconnect electrical power and gas supply.

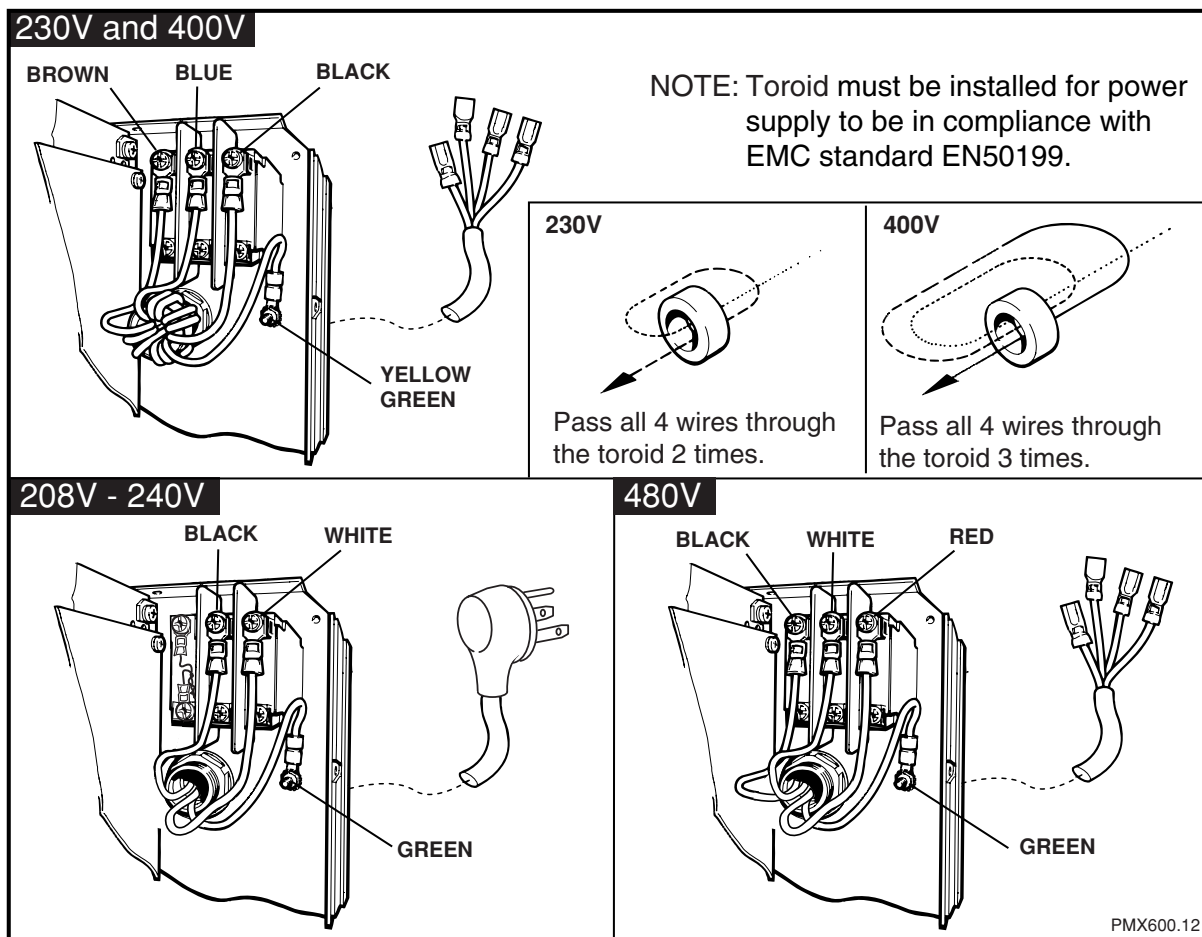

Figure 3-10 Power Cord Replacement

Torch Lead Replacement (For models without quick disconnect)

Disconnect electrical power and gas supply before removing the old torch lead.

Installation - Refer to Figure 3-11.

CAUTION: Do not tighten the strain relief collar (4) onto the torch lead until the gas fitting (3) is tight, or the gas connection may leak.

Install the strain relief (1) and secure with nut (2).

Connect and tighten the gas fitting (3).

Tighten the strain relief collar (4) onto the lead.

Connect the electrical connections (5), (6) and (7).

Tighten terminal block screws to 10 in-lb (12 kg cm) of torque.

Install the power supply cover.

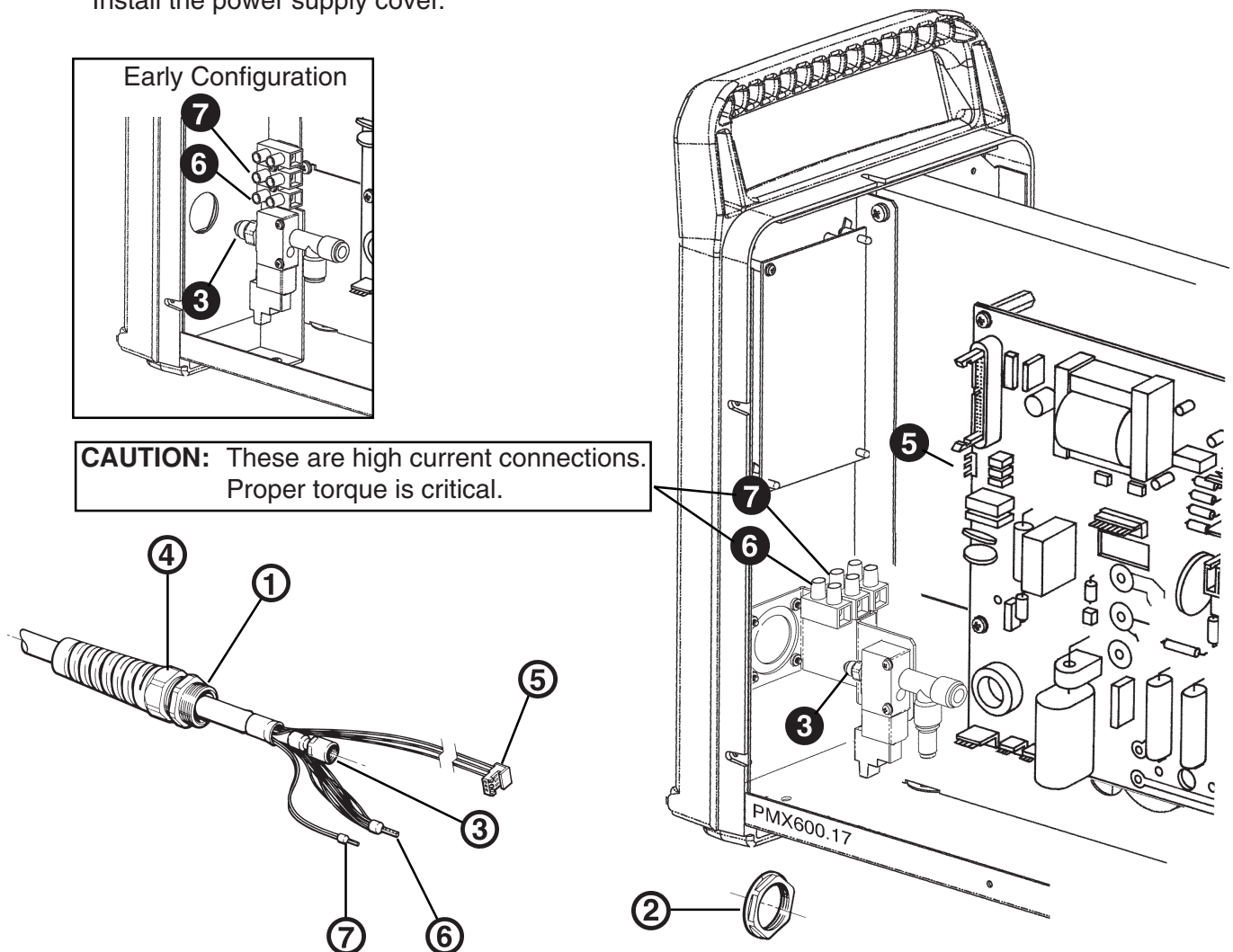

Figure 3-11 Torch Lead Replacement

MAINTENANCE

Air Filter Element Replacement

Removal

- Disconnect electrical power.
 - Disconnect gas supply.
 - Remove the power supply cover.
-

Refer to Figure 3-12.

- ① Compress the hose fitting collar and pull the gas hose from the hose fitting.

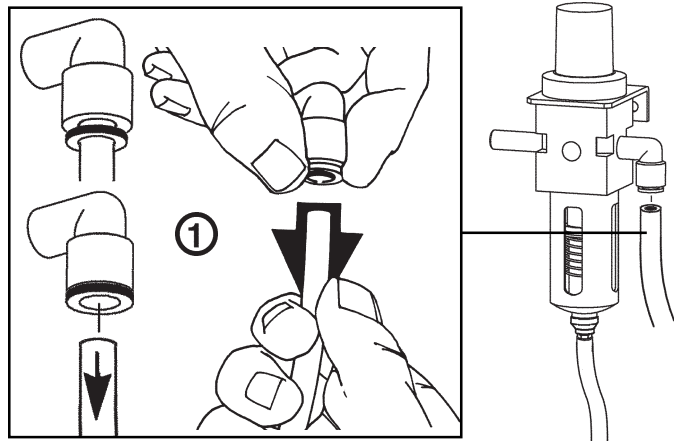

- ② Pull the drain hose from the grommet in the floor of the power supply.

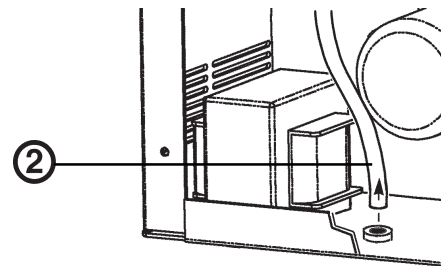

- ③ Unscrew the filter bowl. Do not discard the O-ring.

- ④ Remove the filter element from the filter housing.

NOTE: Do not allow the filter element to turn when loosening the screw.

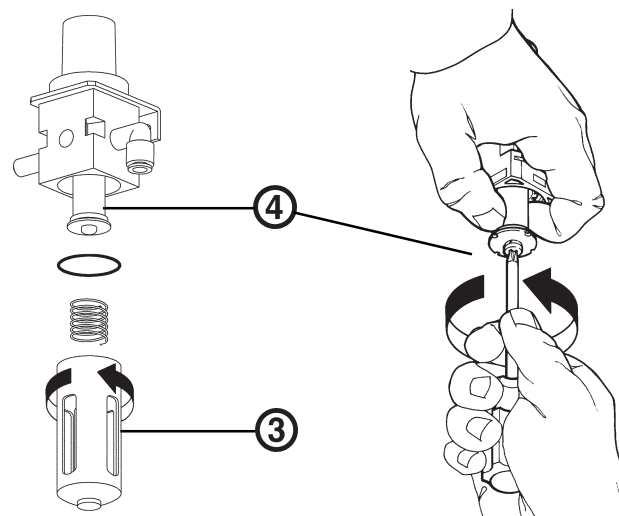
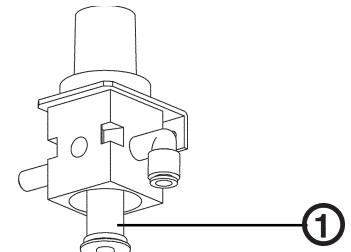

Figure 3-12 Air Filter Element Removal

Air Filter Element Replacement (continued)

Installation - Refer to Figure 3-13.

- ① Install the new filter element into the filter housing. Secure with screw and retainer.



- ② Install the filter bowl and O-ring into the filter housing.

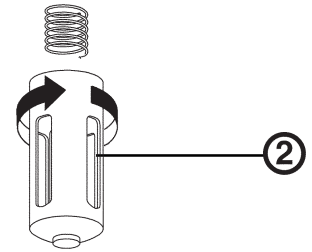

- ③ Push the pressure line fully into the hose fitting.

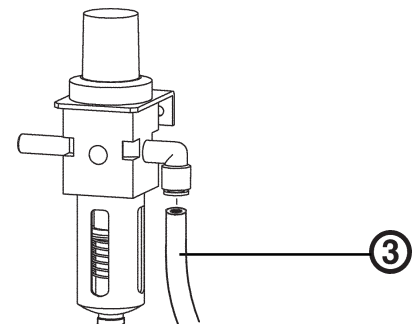

- ④ Install the drain hose into the grommet.

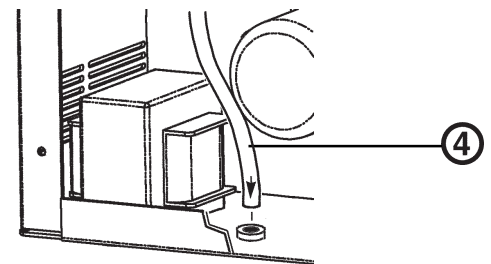

Figure 3-13 Air Filter Element Installation

- Install the power supply cover.
- Connect electrical power.
- Connect gas supply.

MAINTENANCE

Work Cable Replacement

Disconnect electrical power and gas supply before removing the old work cable.

Installation - Refer to Figure 3-14.

Install the strain relief (1) to the power supply and secure with nut (2).

Install work cable (3) through the strain relief.

Tie a knot (4) in the end of the work cable.

Tighten the strain relief collar (5) onto the cable.

Connect the work cable to the terminal block (6).

Tighten terminal block screw to 10 in-lb (12 kg cm) of torque.

Install the power supply cover.

CAUTION: This is a high current connection. Proper torque is critical.

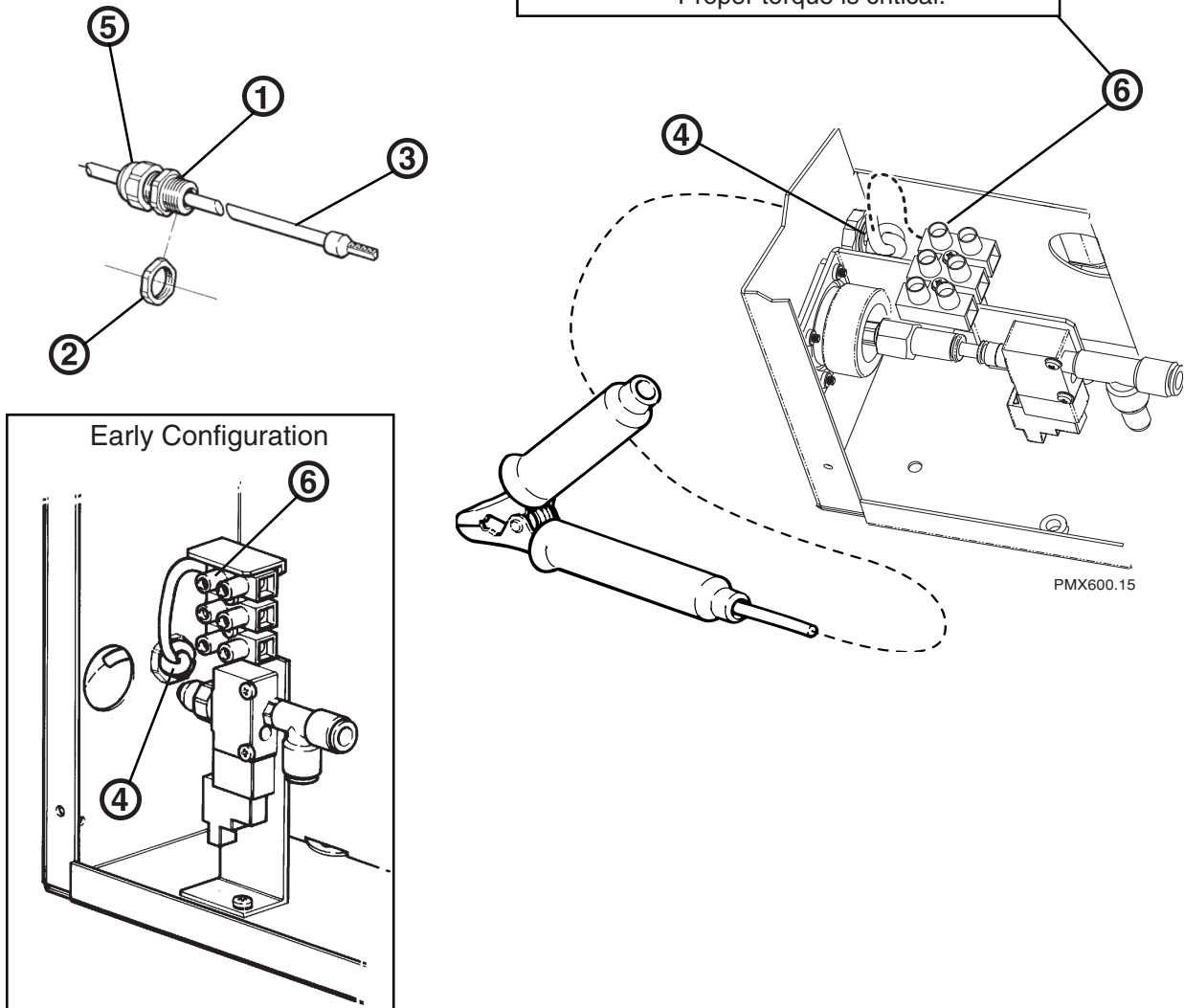

Figure 3-14 Work Cable Replacement

Capacitor Replacement

Removal - Refer to Figure 3-15.

Disconnect electrical power and gas supply before removing the power supply cover.

Remove screws securing capacitor to PC board.

Remove capacitor from fan side of power supply.

Installation - Refer to Figure 3-15.

Check capacitor identification and install as shown below.

Install new capacitor and secure with 2 screws.
Tighten screws to 20 inch pounds (2.26 N-m / 24 kg cm).

Install the power supply cover.

Capacitor Identification

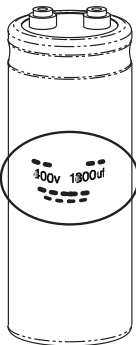
Power Supply	Capacitor Marking	
208/240V	250V 6800uf	
230V	250V 4700uf	
400V	400V 1800uf	
480V	450V 1500uf	

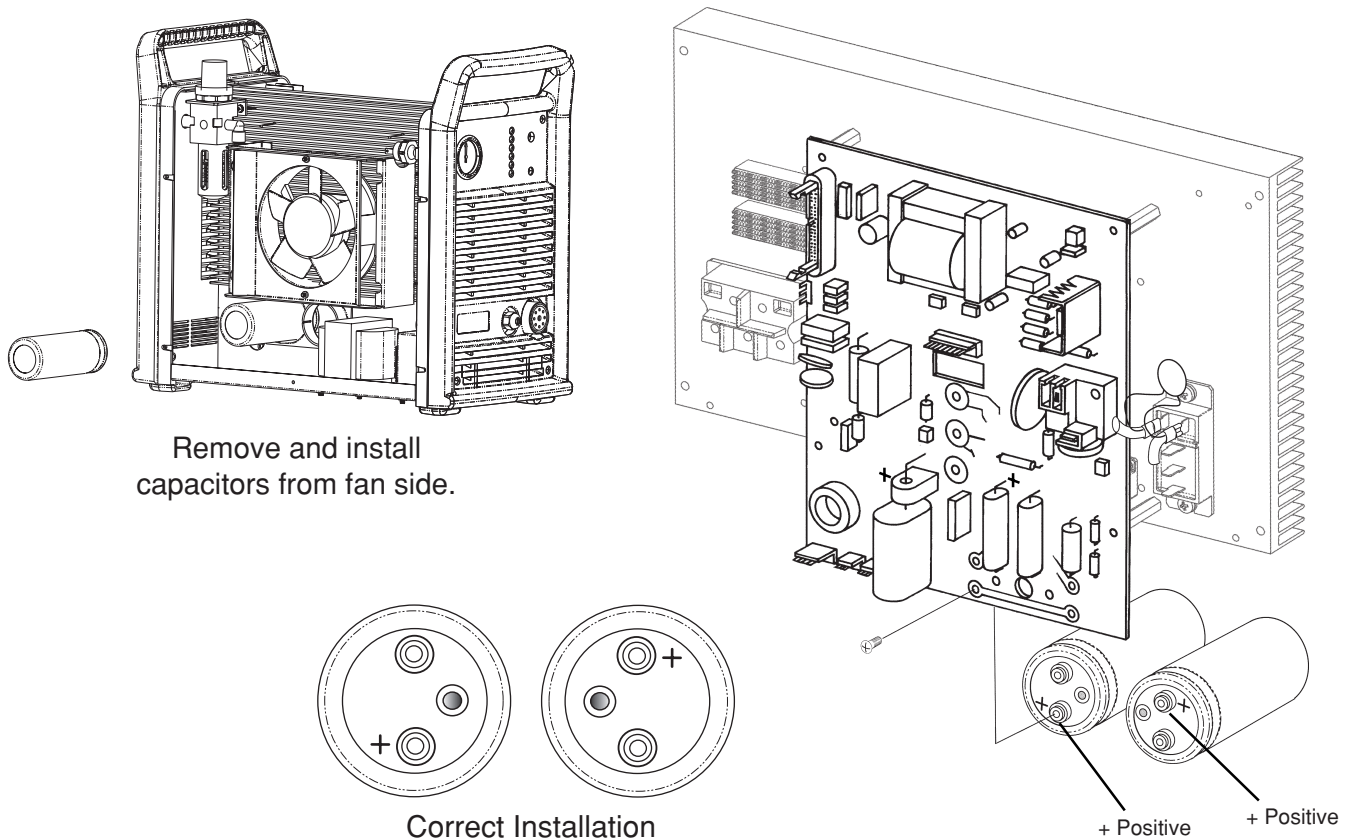

Figure 3-15 Capacitor Replacement

MAINTENANCE

Heat Sink Component Replacement

Installation - Refer to Figure 3-16.

Install components to the heat sink as shown below.

Use a new thermal pad on components C.

Use thermal grease on components A and B.
Apply a thin coat to the component, install with screws, and tighten to required torque.

Re-torque after 2 minutes. Repeat until torque is maintained. Clean excess grease from heat sink.

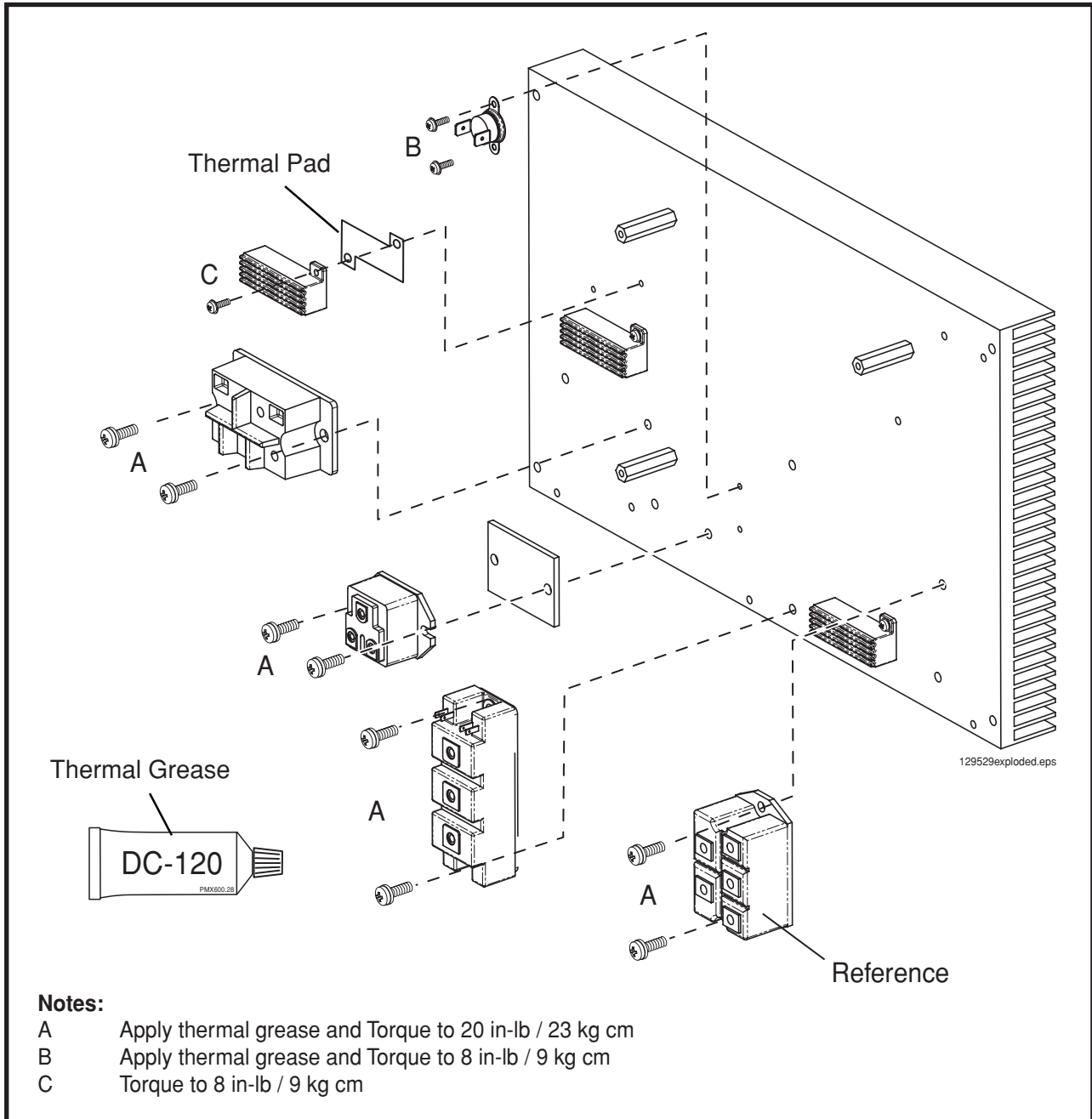

Figure 3-16 Heat Sink Component Replacement

Section 4

PARTS LIST - 400/230V

In this section:

POWER SUPPLY – EXTERIOR	4-2
POWER SUPPLY – FRONT INTERIOR RIGHT SIDE	4-3
POWER SUPPLY – BACK INTERIOR RIGHT SIDE	4-4
POWER SUPPLY – INTERIOR FAN SIDE	4-5
POWER SUPPLY – HEAT SINK ASSEMBLY	4-6
RECOMMENDED SPARE PARTS - POWERMAX600- 230/400V	4-7

PARTS LIST - 400/230V CE

POWER SUPPLY – EXTERIOR

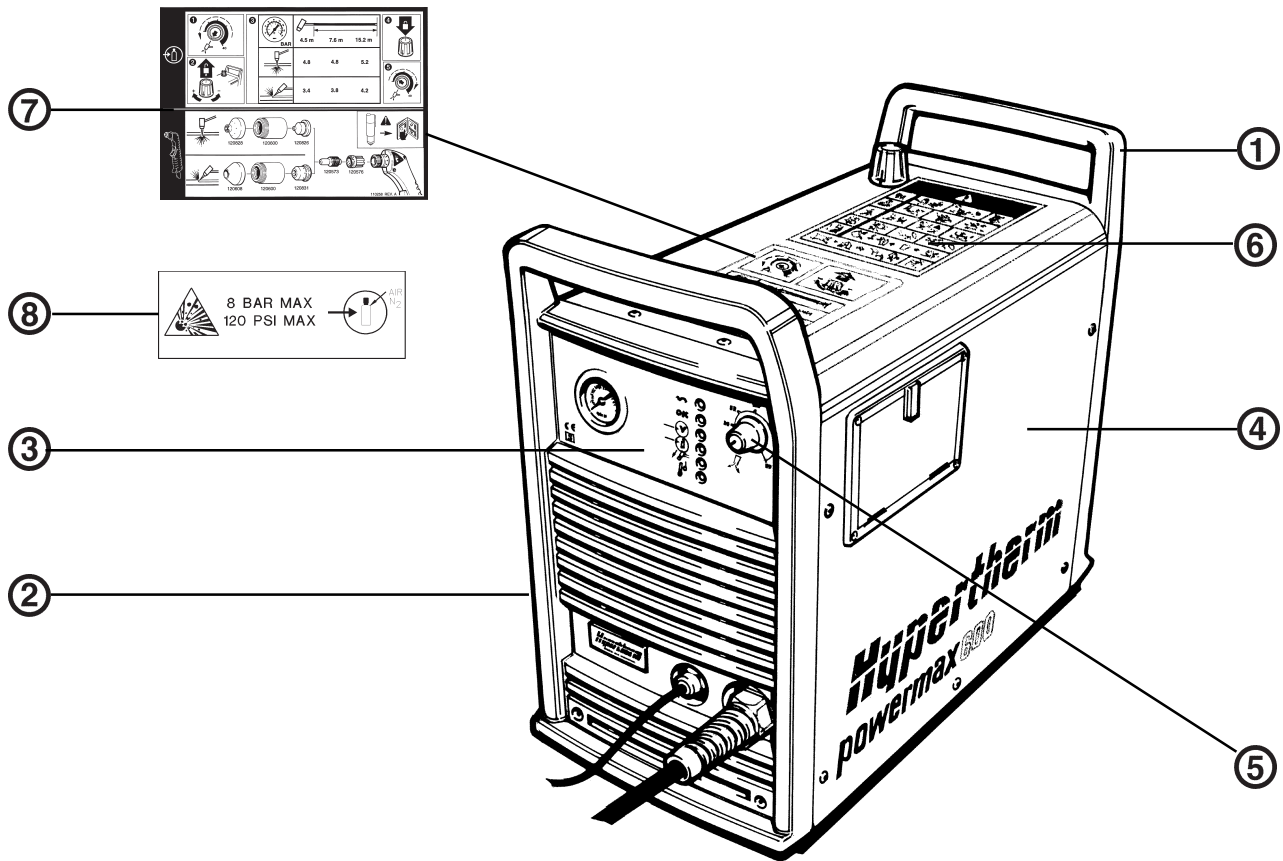

<u>Item</u>	<u>Part Number</u>	<u>Description</u>	<u>Designator</u>	<u>Qty.</u>
1	001669	Rear end panel		1
2	001668	Front end panel (Also order 110242)		1
3	110242	Operation lable		1
4	129488	Power supply cover		1
5	008965	Knob		1
6	110261	Warning label		1
7	110258	Instruction label		1
8	110996	Pressure warning label		1

POWER SUPPLY – FRONT INTERIOR RIGHT SIDE

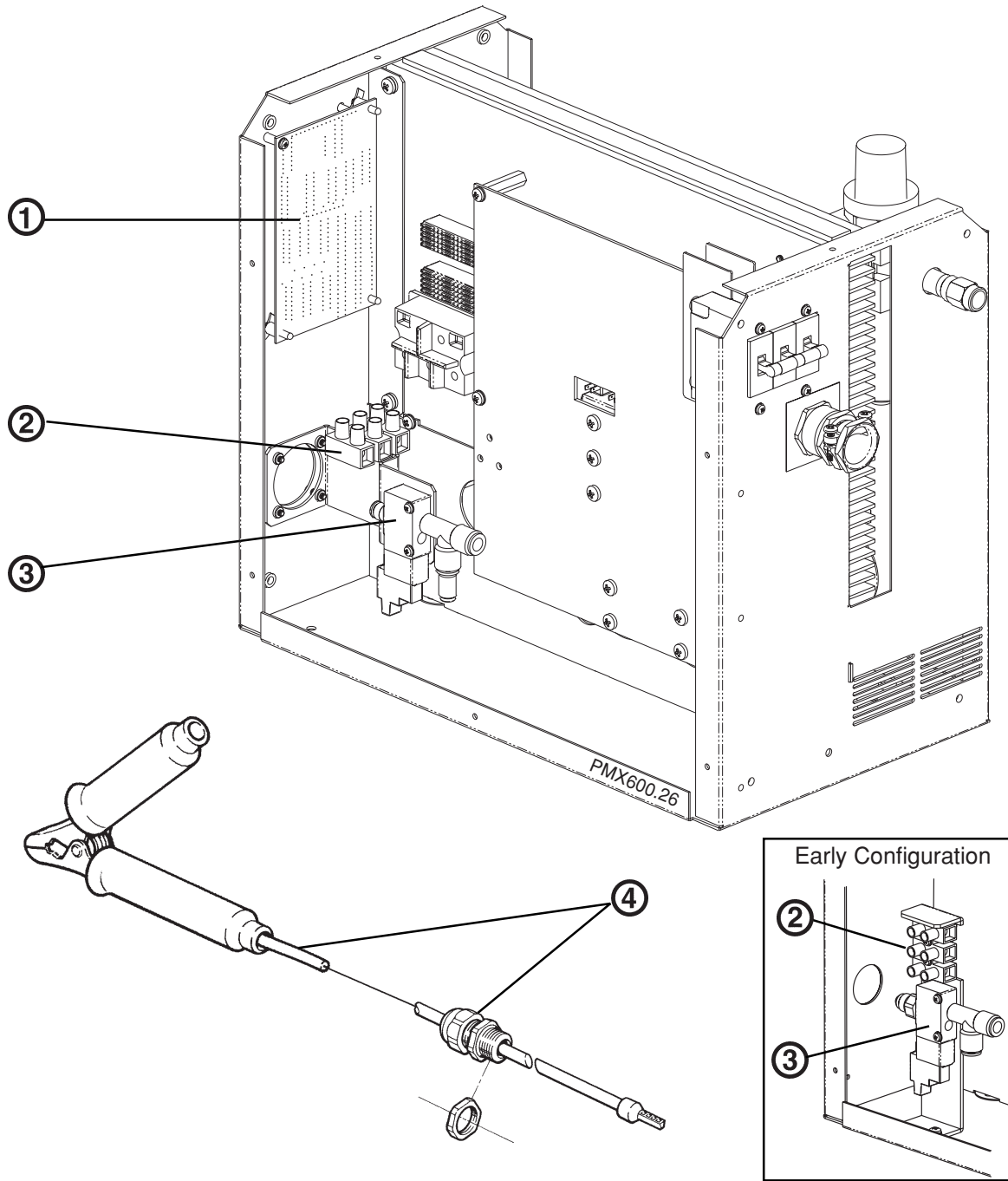

<u>Item</u>	<u>Part Number</u>	<u>Description</u>	<u>Designator</u>	<u>Qty.</u>
1	041593	Control PCB assembly	PCB3	1
2	108090	Terminal block		1
3	129374	Solenoid valve	V1	1
4	123375	Work Cable with clamp, 4.6 m/15 ft		1

POWER SUPPLY – BACK INTERIOR RIGHT SIDE

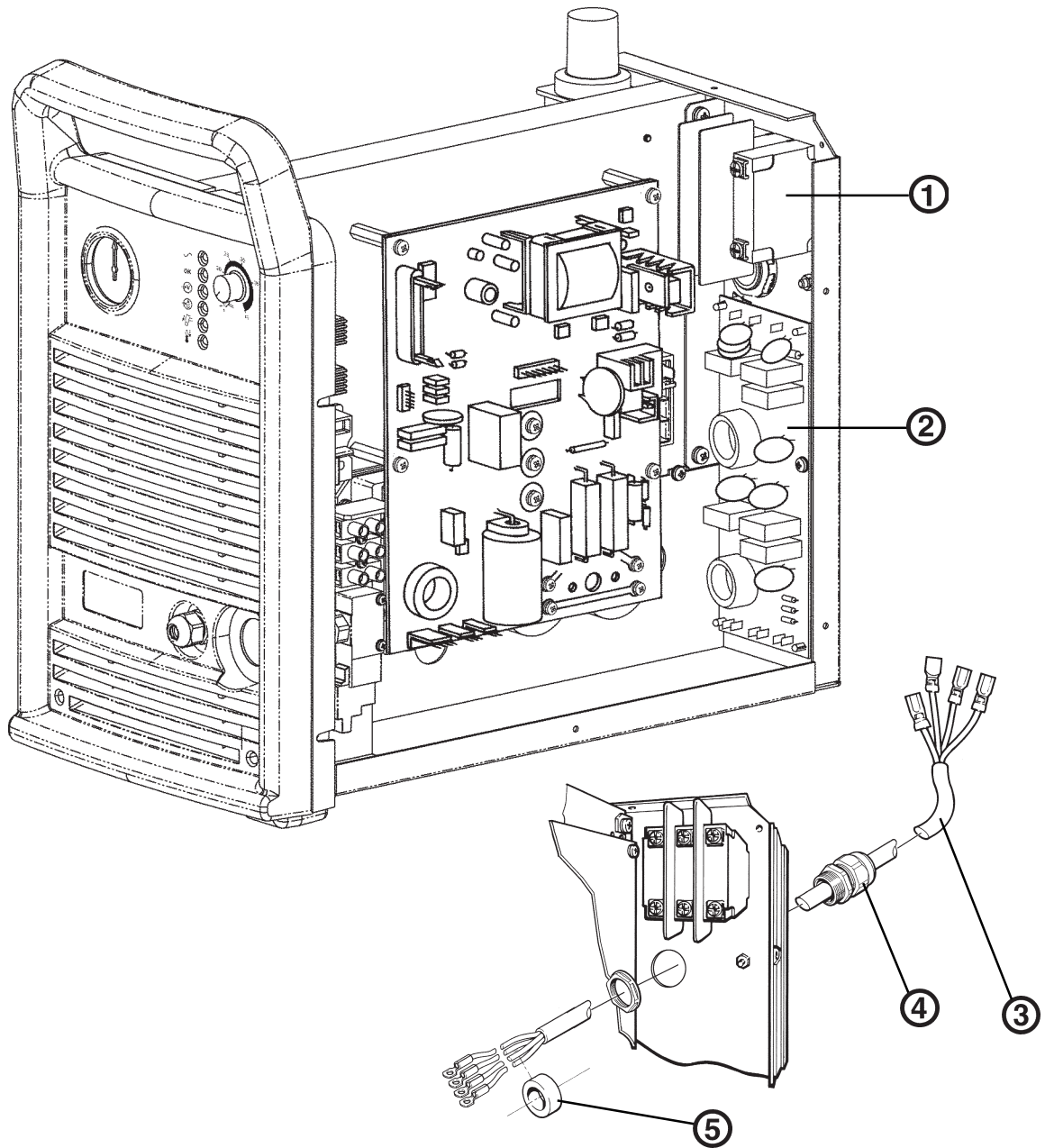

<u>Item</u>	<u>Part Number</u>	<u>Description</u>	<u>Designator</u>	<u>Qty.</u>
1	003193	Circuit breaker, 400 V	S1	1
	003195	Circuit breaker, 230 V	S1	1
2	041566	EMI Filter PCB, 400 V	PCB1	1
	041587	EMI Filter PCB, 230 V	PCB1	1
3	129368	Power cable, 400 V		1
	129410	Power cable, 230 V		1
4	008389	Strain relief, 400 V		1
	108107	Strain relief, 230 V		1
5	109070	Toroid		1

POWER SUPPLY – INTERIOR FAN SIDE

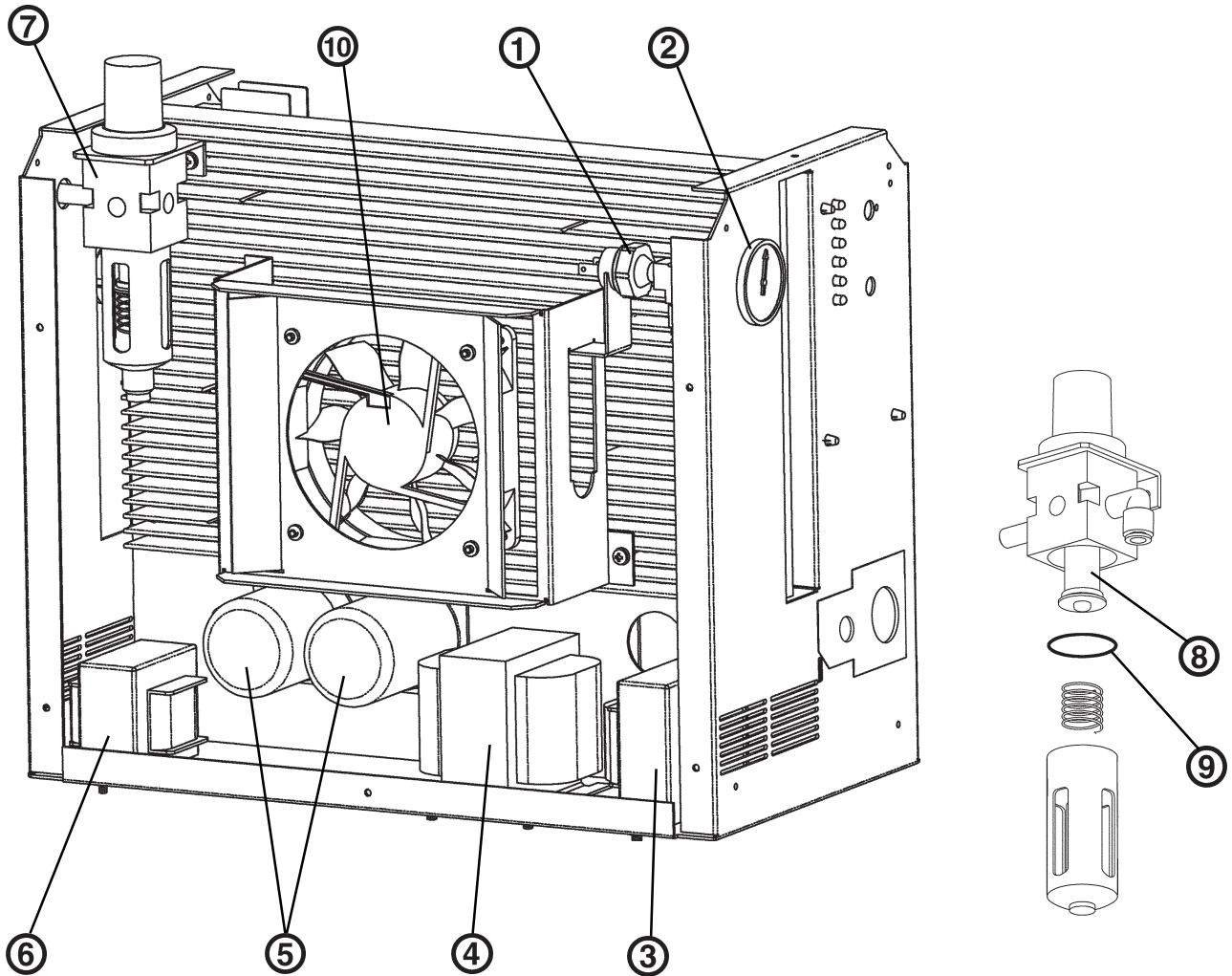

<u>Item</u>	<u>Part Number</u>	<u>Description</u>	<u>Designator</u>	<u>Qty.</u>
1	005112	Pressure Switch	PS1	1
2	022027	Pressure gauge		1
3	014232	Inductor, output choke .80MH 40A	L2	1
4	014234	Power transformer, 400V	T2	1
	014238	Power transformer, 230V	T2	1
5	009999	Capacitor, 1800/1900UF, 400V		2
	109118	Capacitor, 1800/1900UF, 230V		2
6	014231	Inductor, input choke 5MH 11A, 400V	L1	1
	014241	Inductor, input choke 5MH 11A, 230V	L1	1
7	011083	Filter regulator subassembly		1
8	011086	Air filter element		1
9	011087	O-ring		1
10	129366	Fan subassembly	M1	1

PARTS LIST - 400/230V CE

POWER SUPPLY – HEAT SINK ASSEMBLY

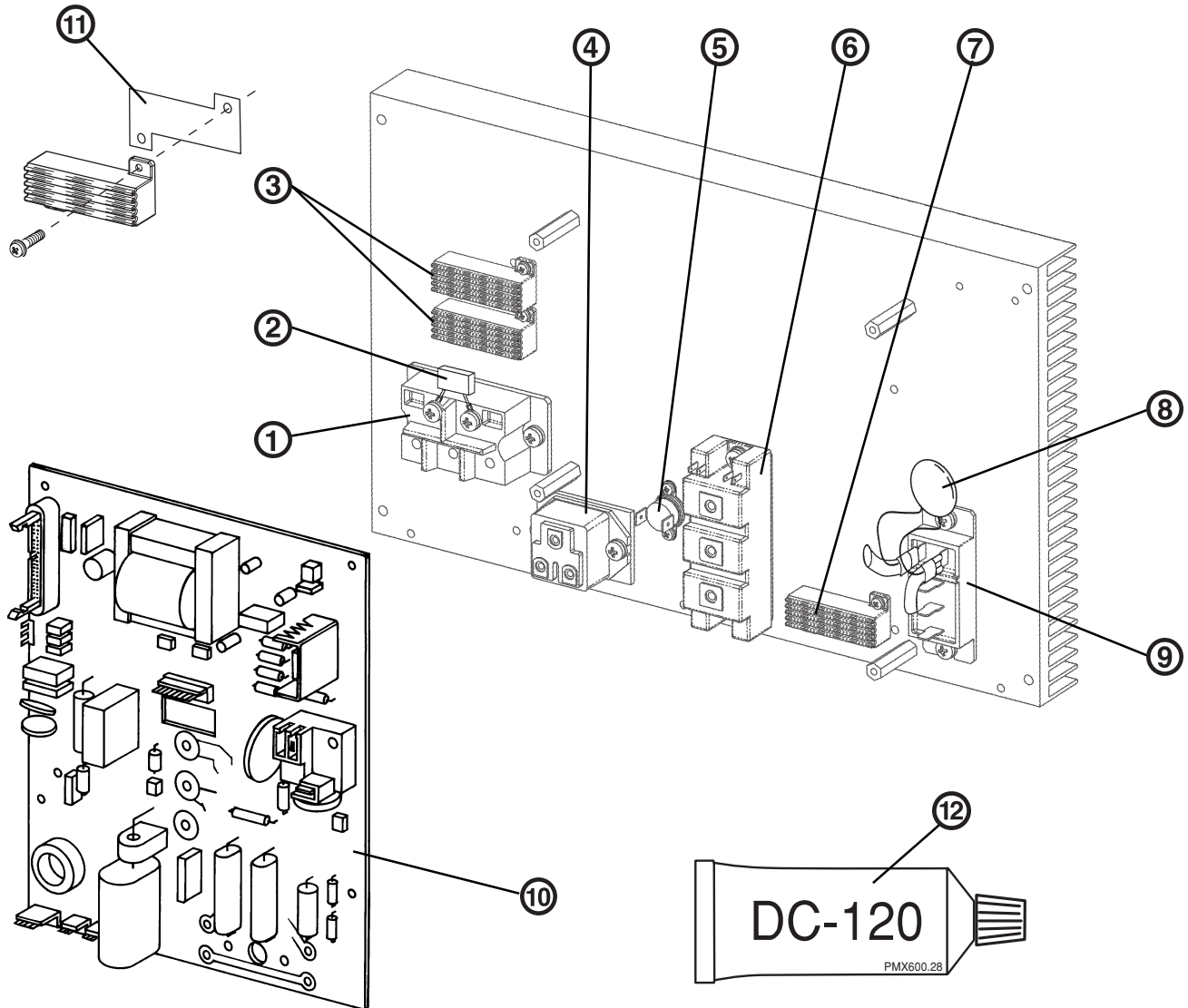

Item	Part Number	Description	Designator	Qty.
1	109088	Output diode	D2	1
2	129406	EMI suppression capacitor		1
3	009849	Resistor, 20 OHM		2
4	109080	IGBT, pilot arc	Q3	1
5	005222	Temp switch	TS1	1
6	109079	IGBT module	Q2	1
7	009849	Resistor, 20 OHM		1
8	109067	MOV		1
9	109090	Input diode bridge, 400V	D1	1
-	109134	Input diode bridge, 230V	D1	1
10	041568	Power PCB, 400V	PCB2	1
-	041607	Power PCB, 230V	PCB2	1
11	008903	Thermal pad		3
12	027662	Thermal grease, 5 oz. tube		5 places

RECOMMENDED SPARE PARTS - POWERMAX600- 230/400V

Part Number Reference	Description	Page
001668	Front end panel	4-2
001669	Rear end panel	4-2
008965	Knob	4-2
110242	Operation lable	4-2
110258	Instruction label	4-2
110261	Warning label	4-2
129488	Power supply cover	4-2
041593	Control PCB assembly	4-3
108090	Terminal block	4-3
123375	Work Cable with clamp, 4.6 m/15 ft	4-3
129374	Solenoid valve	4-3
003193	Circuit breaker, 400 V	4-4
003195	Circuit breaker, 230 V	4-4
041566	EMI Filter PCB, 400 V	4-4
041587	EMI Filter PCB, 230 V	4-4
129368	Power cable, 400 V	4-4
129410	Power cable, 230 V	4-4
005112	Pressure Switch	4-5
009999	Capacitor, 1800/1900UF, 400V	4-5
011083	Filter regulator subassembly	4-5
011086	Air filter element	4-5
011087	O-ring, Air filter element	4-5
014231	Inductor, input choke 5MH 11A, 400V	4-5
014232	Inductor, output choke .80MH 40A	4-5
014234	Power transformer, 400V	4-5
014238	Power transformer, 230V	4-5
014241	Inductor, input choke 5MH 11A, 230V	4-5
022027	Pressure gauge	4-5
109118	Capacitor, 1800/1900UF, 230V	4-5
129366	Fan subassembly	4-5
005222	Temp switch	4-6
009849	Resistor, 20 OHM	4-6
041568	Power PCB, 400V	4-6
041607	Power PCB, 230V	4-6
109067	MOV	4-6
109079	IGBT module	4-6
109080	IGBT, pilot arc	4-6
109088	Output diode	4-6
109090	Input diode bridge, 400V	4-6
109134	Input diode bridge, 230V	4-6
129406	EMI suppression capacitor	4-6
027662	Thermal grease, 5 oz. DC-340	4-6
008903	Thermal pad	4-6

Blank

Section 5

PARTS LIST - 208-240/480V

In this section:

POWER SUPPLY – EXTERIOR	5-2
POWER SUPPLY – FRONT INTERIOR RIGHT SIDE	5-3
POWER SUPPLY – CIRCUIT BREAKER AND POWER CABLE	5-4
POWER SUPPLY – INTERIOR FAN SIDE	5-5
POWER SUPPLY – HEAT SINK ASSEMBLY	5-6
RECOMMENDED SPARE PARTS - POWERMAX600- 208-240/480V	5-7

PARTS LIST - 208-240/480V

POWER SUPPLY – EXTERIOR

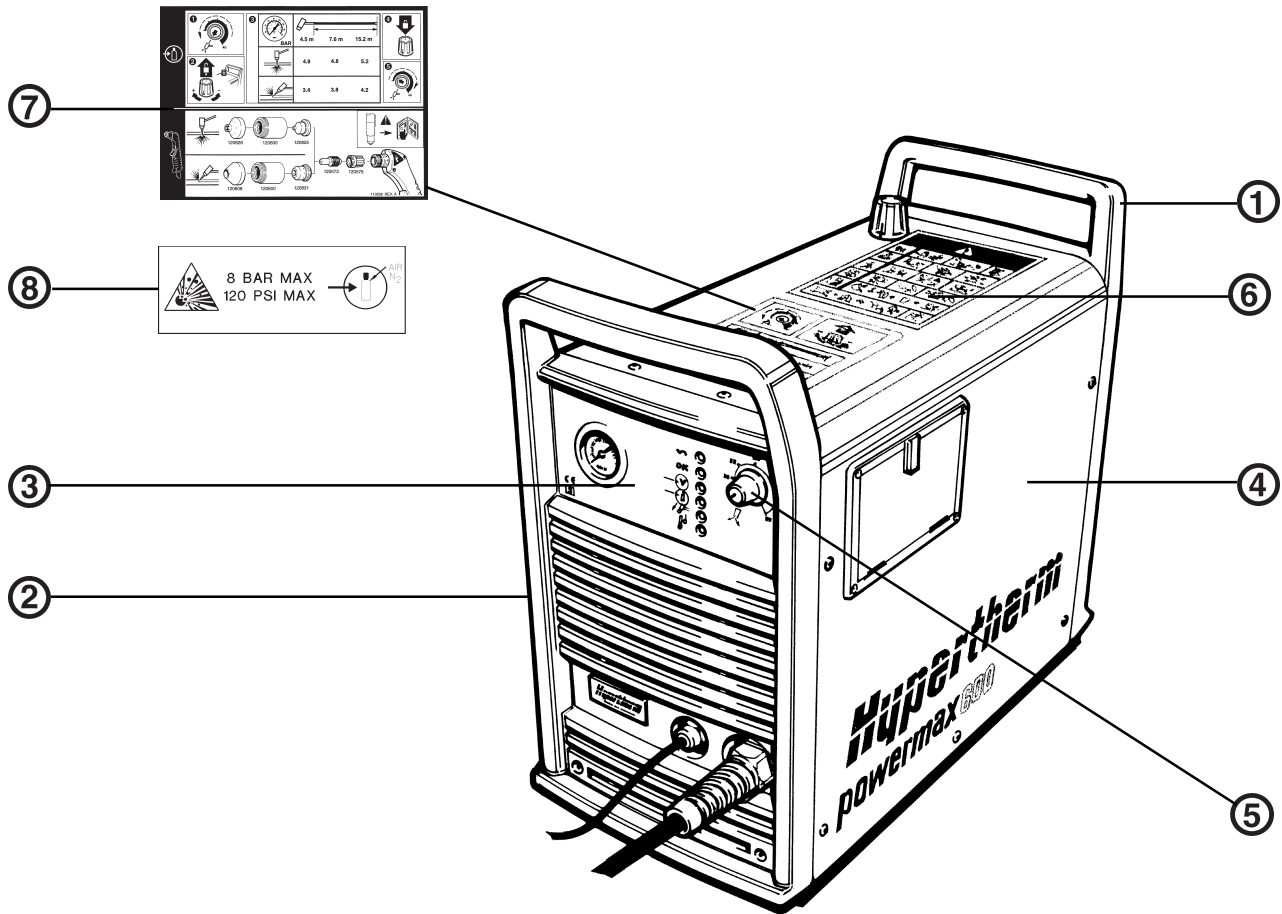

<u>Item</u>	<u>Part Number</u>	<u>Description</u>	<u>Designator</u>	<u>Qty.</u>
1	001669	Rear end panel		1
2	001668	Front end panel (also order 110271)		1
3	110271	Operation lable		1
4	129594	Power supply cover		1
5	008965	Knob		1
6	010287	Warning label		1
7	110276	Instruction label		1
8	110996	Pressure warning label		1

POWER SUPPLY – FRONT INTERIOR RIGHT SIDE

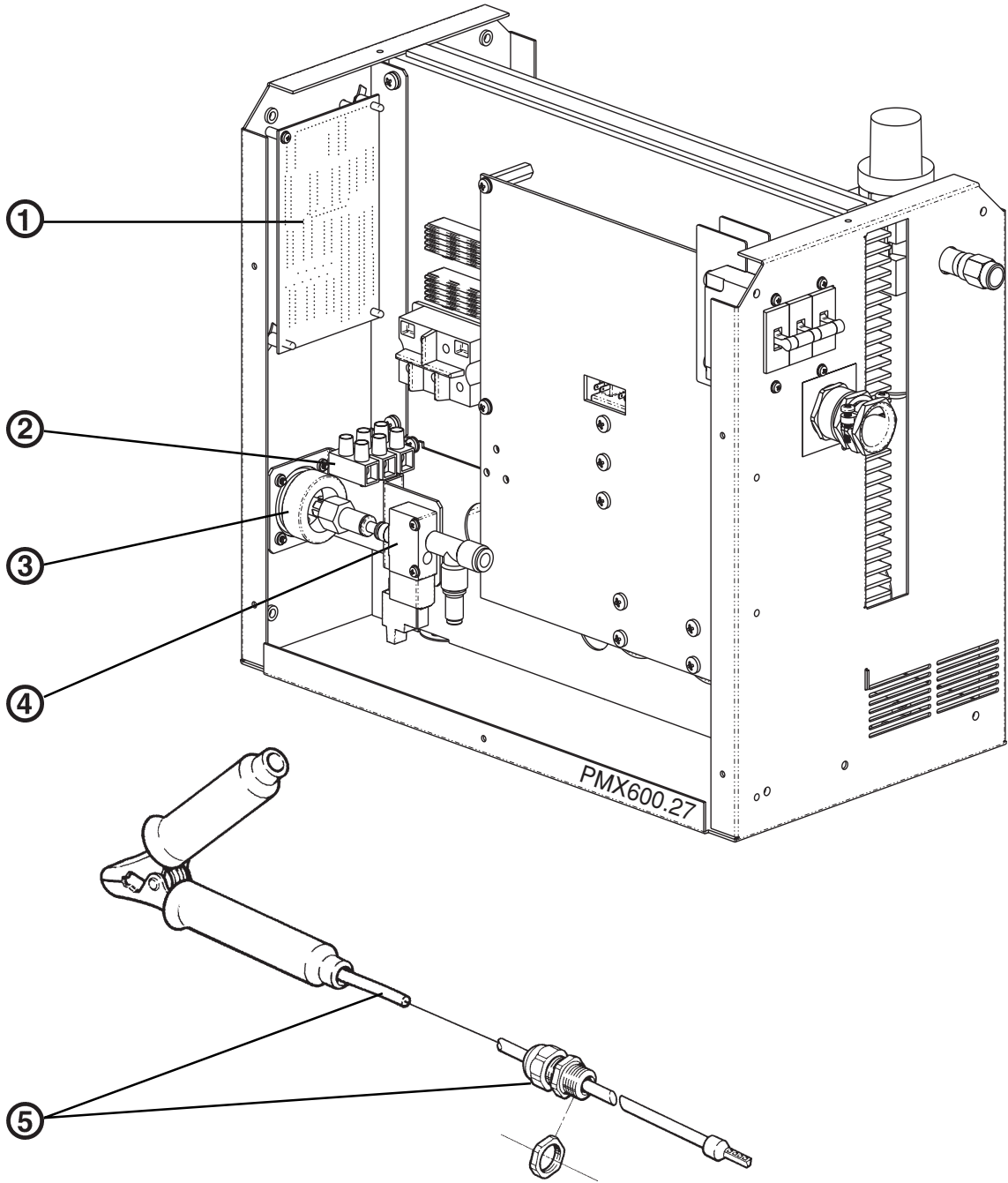

<u>Item</u>	<u>Part Number</u>	<u>Description</u>	<u>Designator</u>	<u>Qty.</u>
1	041654	Control PCB assembly	PCB3	1
2	108090	Terminal block		1
3	129534	Quick disconnect assembly		1
4	129533	Solenoid valve	V1	1
5	123375	Work Cable with clamp, 4.6 m/15 ft		1

PARTS LIST - 208-240/480V

POWER SUPPLY – CIRCUIT BREAKER AND POWER CABLE

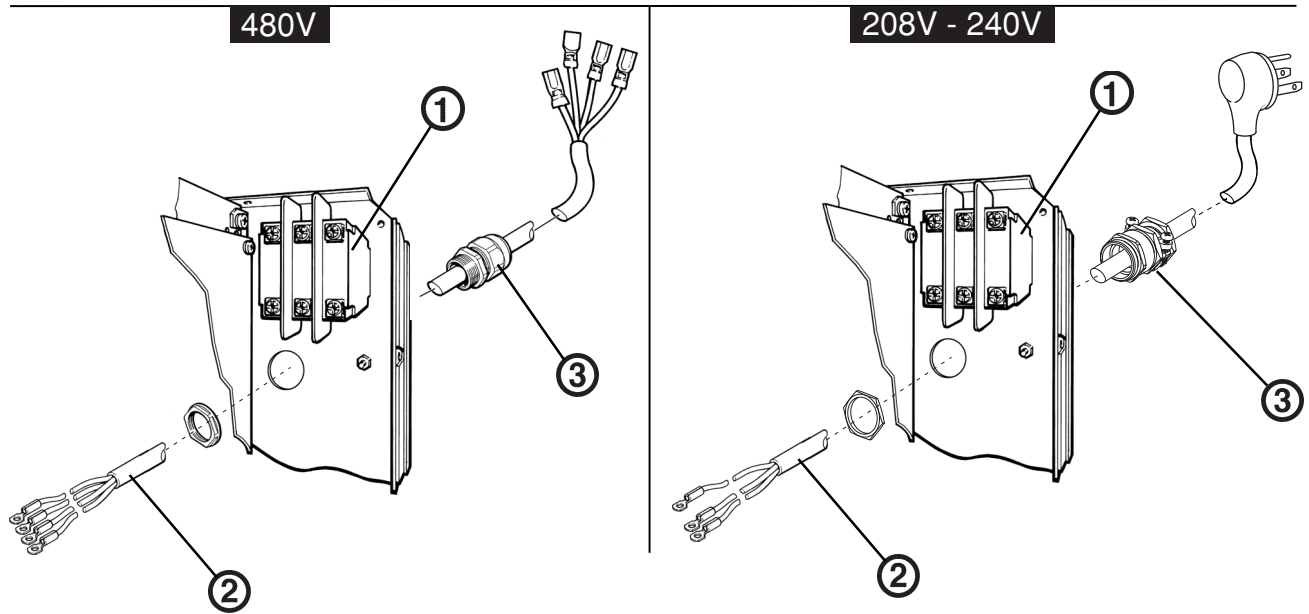

<u>Item</u>	<u>Part Number</u>	<u>Description</u>	<u>Designator</u>	<u>Qty.</u>
1	003193	Circuit breaker, 480V	S1	1
	003202	Circuit breaker, 208-230V	S1	1
2	023519	Power cable, 480V		1
	129530	Power cable, 208-230V		1
3	108124	Strain relief, 480V		1
	108122	Strain relief, 208-230V		1

POWER SUPPLY – INTERIOR FAN SIDE

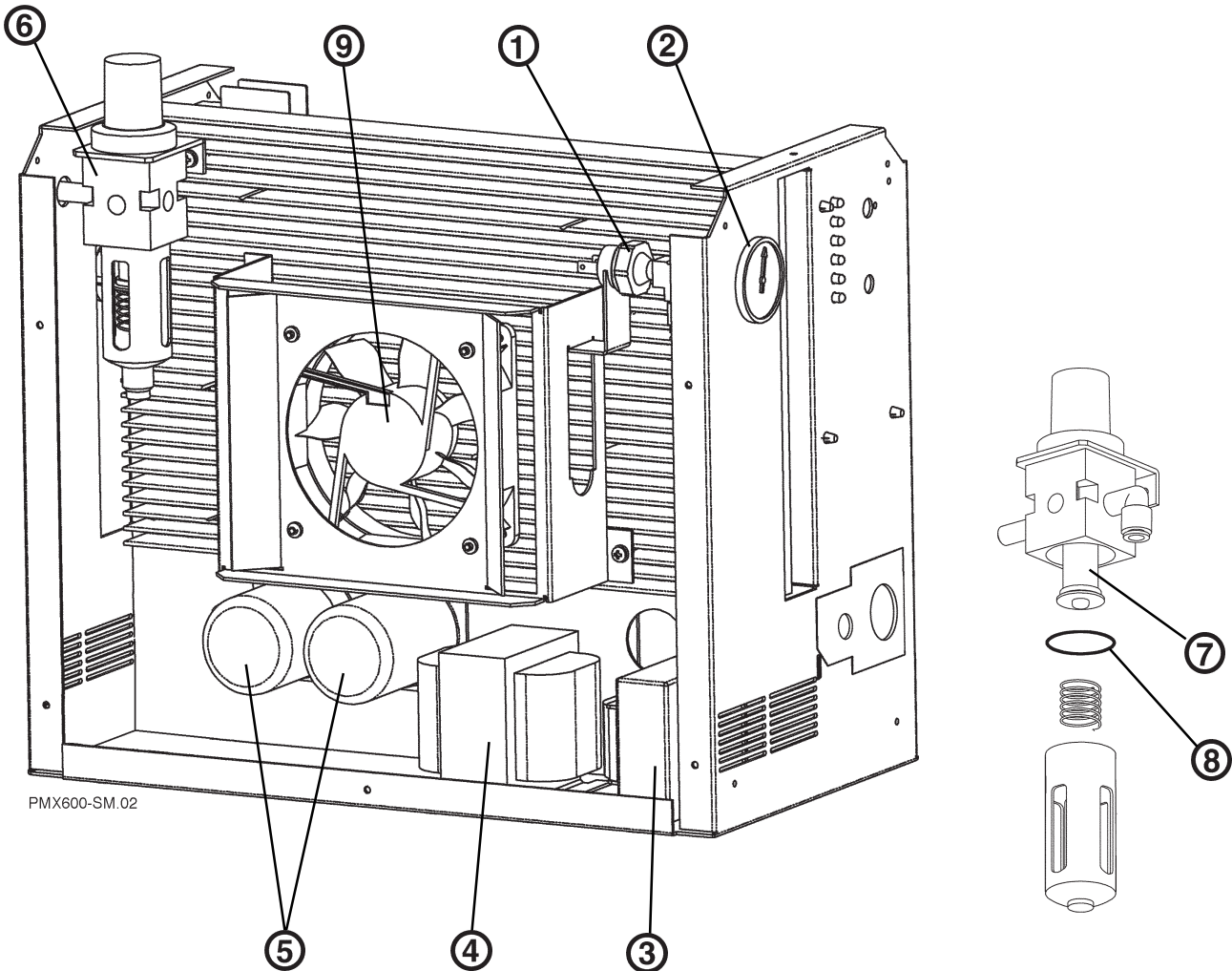

<u>Item</u>	<u>Part Number</u>	<u>Description</u>	<u>Designator</u>	<u>Qty.</u>
1	005112	Pressure Switch	PS1	1
2	022027	Pressure gauge		1
3	014232	Inductor, output choke .80MH 40A	L2	1
4	014252	Power transformer, 480V	T2	1
	014251	Power transformer, 208-230V	T2	1
5	109179	Capacitor, 1800/1900UF 450V, 480V		2
	109187	Capacitor, 1800/1900UF 250V, 208-230V		2
6	011083	Filter regulator subassembly		1
7	011086	Air filter element		1
8	011087	O-ring		1
9	129366	Fan subassembly, 480V	M1	1
	027654	Fan assembly, 208-230V	M1	1

POWER SUPPLY – HEAT SINK ASSEMBLY

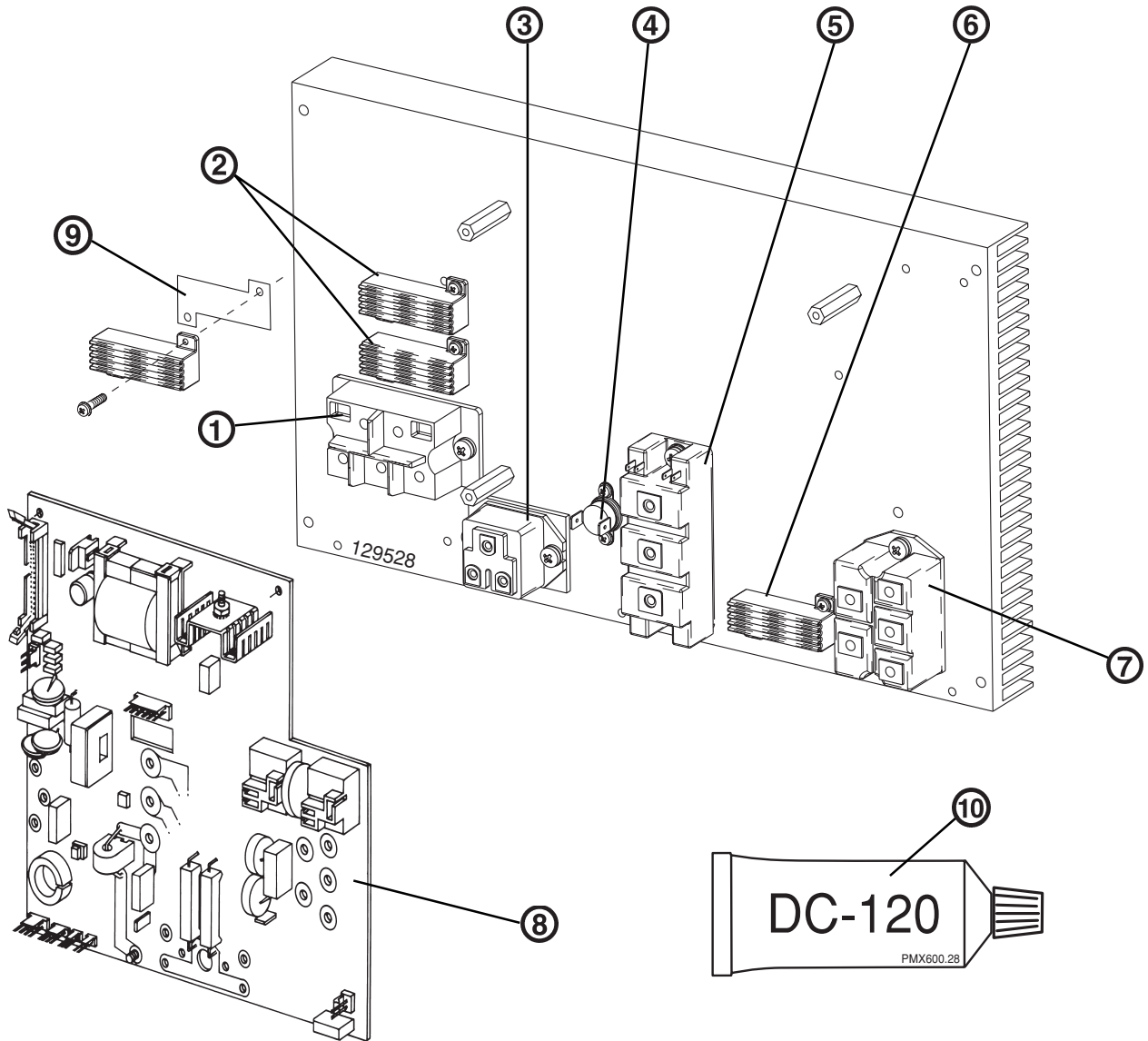

<u>Item</u>	<u>Part Number</u>	<u>Description</u>	<u>Designator</u>	<u>Qty.</u>
1	109088	Output diode	D2	1
2	009849	Resistor, 20 OHM		2
3	109080	IGBT, pilot arc	Q3	1
4	005222	Temp switch	TS1	1
5	109079	IGBT module, 480V	Q2	1
6	109183	IGBT module, 208-240V	Q2	1
7	009849	Resistor, 20 OHM		1
-	109175	Input diode bridge, 480V	D18	1
-	109174	Input diode bridge, 208-240V	D18	1
8	041652	Power PCB, 480V	PCB2	1
-	041650	Power PCB, 208-240V	PCB2	1
9	008903	Thermal pad		3
10	027662	Thermal grease, 5 oz. tube		5 places

RECOMMENDED SPARE PARTS - POWERMAX600- 208-240/480V

Part Number Reference	Description	Page
001668	Front end panel	5-2
001669	Rear end panel	5-2
008965	Knob	5-2
010287	Warning label	5-2
110271	Operation lable	5-2
129594	Power supply cover	5-2
041654	Control PCB assembly	5-3
108090	Terminal block	5-3
123375	Work Cable with clamp, 4.6 m/15 ft	5-3
129533	Solenoid valve	5-3
129534	Quick disconnect assembly	5-3
003193	Circuit breaker, 480 V	5-4
003202	Circuit breaker, 208-230V	5-4
023519	Power cable, 480V	5-4
129530	Power cable, 208-230V	5-4
005112	Pressure Switch	5-5
011083	Filter regulator subassembly	5-5
011086	Air filter element	5-5
011087	O-ring, Air filter element	5-5
014232	Inductor, output choke .80MH 40A	5-5
014251	Power transformer, 208-240V	5-5
022027	Pressure gauge	5-5
027654	Fan assembly	5-5
014252	Power transformer, 480V	5-5
109179	Capacitor, 1800/1900UF 450V, 480V	5-5
109187	Capacitor, 1800/1900UF 250V, 208-230V	5-5
129366	Fan subassembly, 480V	5-5
005222	Temp switch	5-6
009849	Resistor, 20 OHM	5-6
041650	Power PCB, 208-240V	5-6
041652	Power PCB, 480V	5-6
109079	IGBT module, 480V	5-6
109080	IGBT, pilot arc	5-6
109088	Output diode	5-6
109174	Input diode bridge, 208-240V	5-6
109175	Input diode bridge, 480V	5-6
109183	IGBT module, 208-240V	5-6
027662	Thermal grease, 5 oz. DC-340	5-6
008903	Thermal pad	5-6

Blank

Section 6

PARTS LIST - TORCH AND CONSUMABLES

In this section:

PAC123T HAND TORCH ASSEMBLY (NO QUICK DISCONNECT)	6-2
PAC123T HAND TORCH ASSEMBLY (WITH QUICK DISCONNECT)	6-4
PAC123M MACHINE TORCH ASSEMBLY (NO QUICK DISCONNECT)	6-6
PAC123M MACHINE TORCH ASSEMBLY (WITH QUICK DISCONNECT)	6-8
TORCH CONSUMABLES	6-10
RECOMMENDED SPARE PARTS - PAC123 TORCH	6-11

PARTS LIST - TORCH AND CONSUMABLES

PAC123T Hand Torch Assembly (No Quick Disconnect)

Item	Part Number	Description	Quantity
	086001*	PAC123T Hand Torch Assembly with 15 ft / 4.5 m Lead (No Quick Disconnect)	
	086002*	PAC123T Hand Torch Assembly with 25 ft / 7.5 m Lead (No Quick Disconnect)	
	086003*	PAC123T Hand Torch Assembly with 50 ft / 15 m Lead (No Quick Disconnect)	
1	001288	Handle, 2 Sides	1
2	002244	Safety Trigger	1
3	128377	Replacement Start Switch (switch and wire splices)	1
4	027254	Trigger Spring	1
5	004764	Retaining Ring, Gutcha	1
6	075339	Screws, P/S, # 4 X 1/2, PH, RND, S/B	5
7	120570	Torch Main Body with Safety Switch	1
8	044016	O-Ring: BUNA 90 Duro .614X.070	1
9	129475	Replacement Hand Torch Lead, 15 ft / 4.5 m	1
9	129476	Replacement Hand Torch Lead, 25 ft / 7.5 m	1
9	129477	Replacement Hand Torch Lead, 50 ft / 15 m	1

* Top assembly includes the following consumables:

120573	Electrode	1
120576	Swirl Ring	1
120600	Retaining Cap	1
120826	Nozzle	1
120828	Shield	1

PARTS LIST - TORCH AND CONSUMABLES

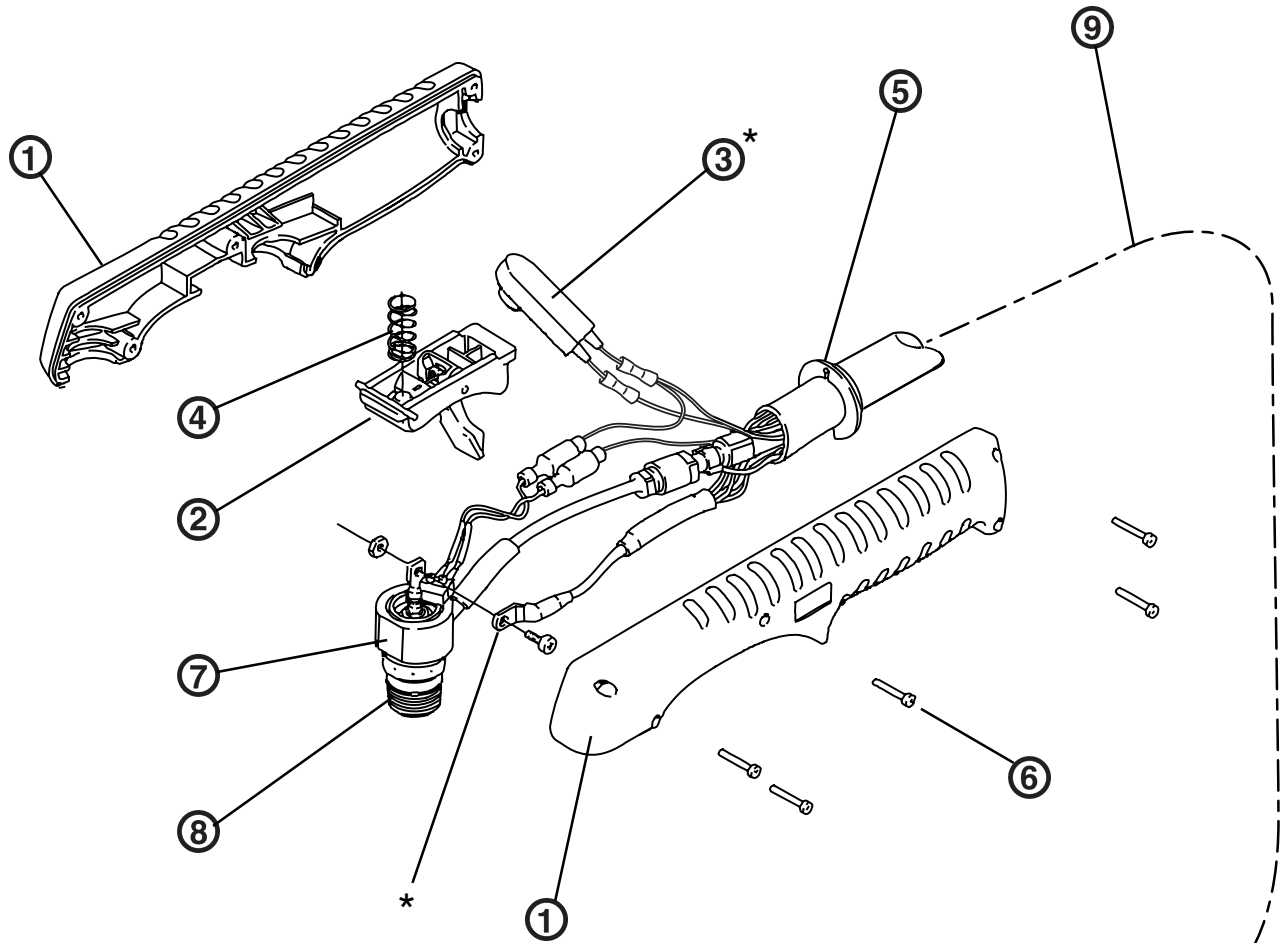

* Included with replacement lead assembly.

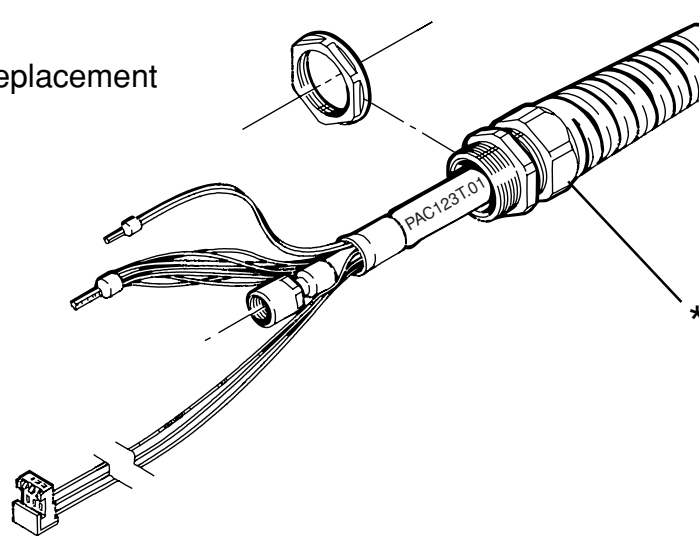

PAC123T Hand Torch and Lead Assembly - No Quick Disconnect

PARTS LIST - TORCH AND CONSUMABLES

PAC123T Hand Torch Assembly (With Quick Disconnect)

Item	Part Number	Description	Quantity
	086023*	PAC123T Hand Torch Assembly with 15 ft / 4.5 m Lead and Quick Disconnect	
	086024*	PAC123T Hand Torch Assembly with 25 ft / 7.5 m Lead and Quick Disconnect	
	086025*	PAC123T Hand Torch Assembly with 50 ft / 15 m Lead and Quick Disconnect	
1	001288	Handle, 2 Sides	1
2	002244	Safety Trigger	1
3	128377	Replacement Start Switch (switch and wire splices)	1
4	027254	Trigger Spring	1
5	004764	Retaining Ring, Gutcha	1
6	075339	Screws, P/S, # 4 X 1/2, PH, RND, S/B	5
7	120570	Torch Main Body with Safety Switch	1
8	044016	O-Ring: BUNA 90 Duro .614X.070	1
9	129599	Replacement Hand Torch Lead, 15 ft / 4.5 m	1
9	129600	Replacement Hand Torch Lead, 25 ft / 7.5 m	1
9	129601	Replacement Hand Torch Lead, 50 ft / 15 m	1

* Top assembly includes the following consumables:

120573	Electrode	1
120576	Swirl Ring	1
120600	Retaining Cap	1
120826	Nozzle	1
120828	Shield	1

PARTS LIST - TORCH AND CONSUMABLES

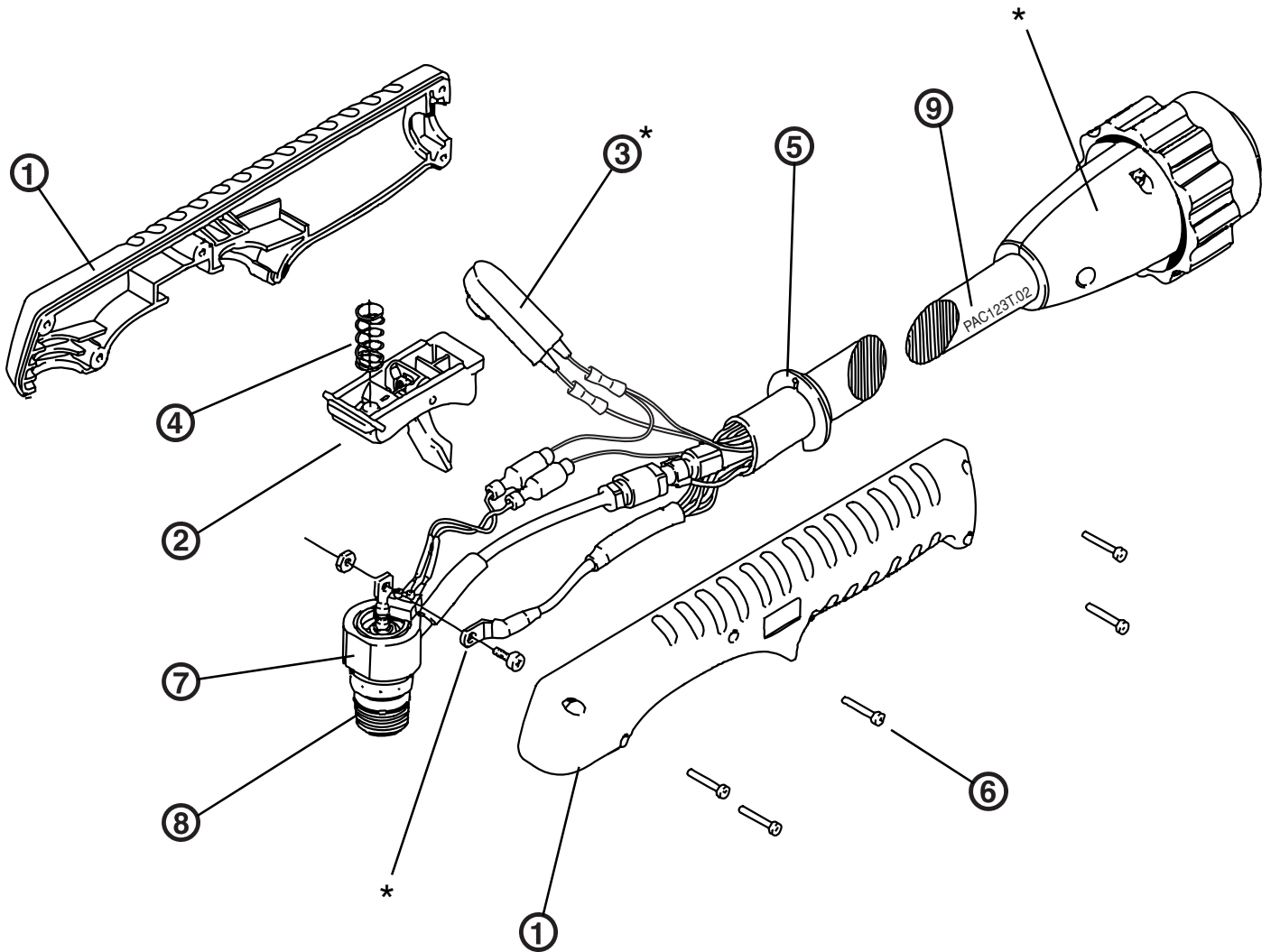

* Included with replacement lead assembly.

PAC123T Hand Torch and Lead Assembly - With Quick Disconnect

PARTS LIST - TORCH AND CONSUMABLES

PAC123M Machine Torch Assembly (No Quick Disconnect)

Item	Part Number	Description	Quantity
	086004*	PAC123M Machine Torch Assembly with 15 ft / 4.5 m Lead (No Quick Disconnect)	
	086005*	PAC123M Machine Torch Assembly with 25 ft / 7.5 m Lead (No Quick Disconnect)	
	086006*	PAC123M Machine Torch Assembly with 50 ft / 15 m Lead (No Quick Disconnect)	
1	120613	Sleeve, Machine Torch	1
2	020620	Sleeve, Torch Position	1
3	128374	Replacement Torch Lead, 15 ft / 4.5 m	1
3	128375	Replacement Torch Lead, 25 ft / 7.5 m	1
3	128376	Replacement Torch Lead, 50 ft / 15 m	1
4	027599	Snap Ring	1
5	120583	Torch Main Body with Safety Switch	1
6	044016	O-Ring: BUNA 90 Duro 0.614 X 0.070 inch	1
7	028714	On/Off Pendant with Lead, 25 ft / 7.5 m	
	128061	On/Off Pendant with Lead, 50 ft / 15 m	
	128062	On/Off Pendant with Lead, 75 ft / 23 m	

* Top assembly includes the following consumables:

120573	Electrode	1
120576	Swirl Ring	1
120600	Retaining Cap	1
120826	Nozzle	1
120827	Shield	1

PARTS LIST - TORCH AND CONSUMABLES

* Included with replacement lead assembly.

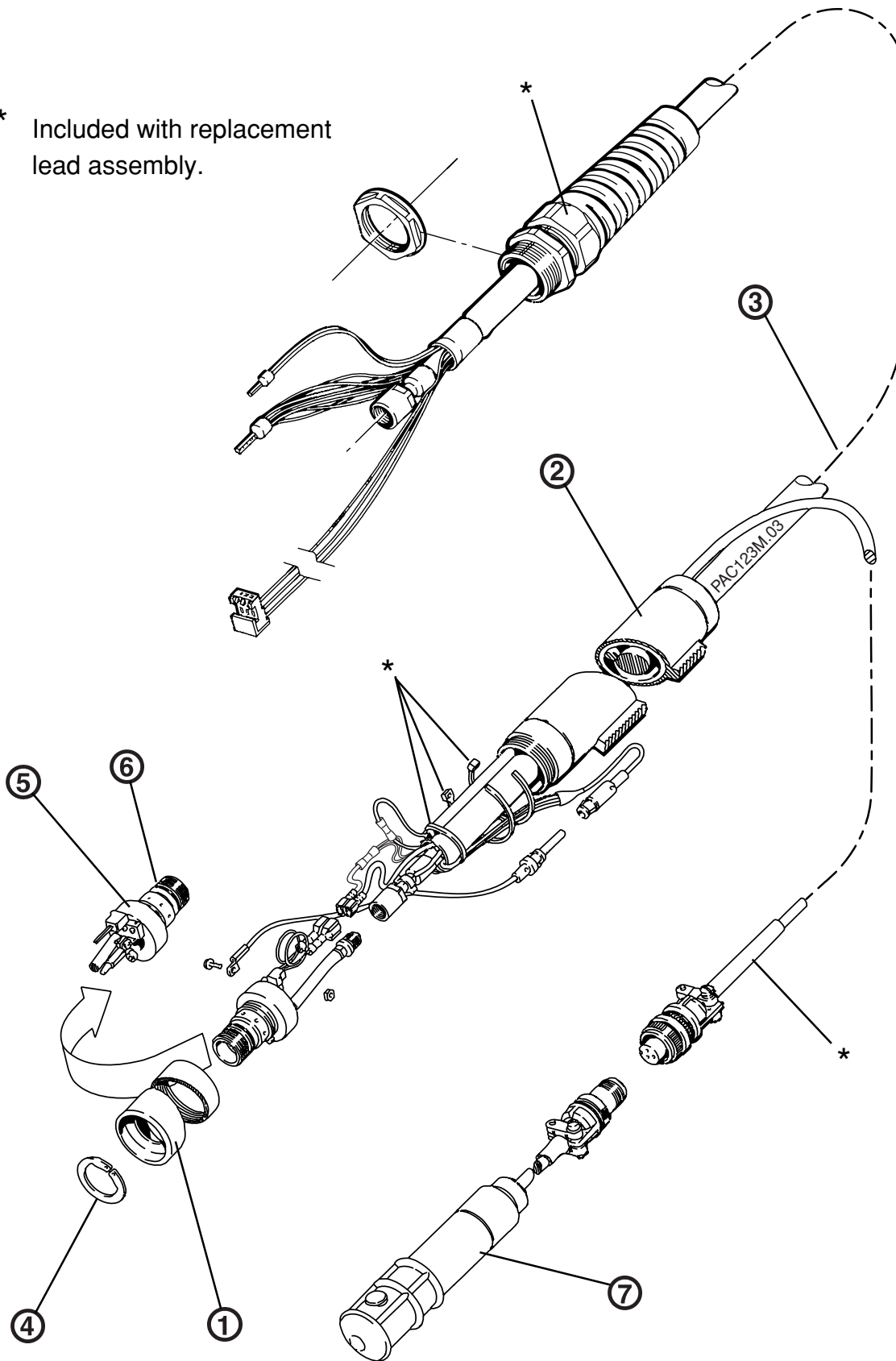

PAC123M Machine Torch Assembly and Leads - No Quick Disconnect

PARTS LIST - TORCH AND CONSUMABLES

PAC123M Machine Torch Assembly (With Quick Disconnect)

Item	Part Number	Description	Quantity
	086026*	PAC123M Machine Torch Assembly with 15 ft / 4.5 m Lead and Quick Disconnect	
	086027*	PAC123M Machine Torch Assembly with 25 ft / 7.5 m Lead and Quick Disconnect	
	086029*	PAC123M Machine Torch Assembly with 50 ft / 15 m Lead and Quick Disconnect	
1	120613	Sleeve, Machine Torch	1
2	020620	Sleeve, Torch Position	1
3	128572	Replacement Torch Lead w/Quick Disconnect, 15 ft / 4.5 m	1
3	128573	Replacement Torch Lead w/Quick Disconnect, 25 ft / 7.5 m	1
3	128574	Replacement Torch Lead w/Quick Disconnect, 50 ft / 15 m	1
4	027599	Snap Ring	1
5	120583	Torch Main Body with Safety Switch	1
6	044016	O-Ring: BUNA 90 Duro 0.614 X 0.070 inch	1
7	028714	On/Off Pendant with Lead, 25 ft / 7.5 m	
	128061	On/Off Pendant with Lead, 50 ft / 15 m	
	128062	On/Off Pendant with Lead, 75 ft / 23 m	

* Top assembly includes the following consumables:

120573	Electrode	1
120576	Swirl Ring	1
120600	Retaining Cap	1
120826	Nozzle	1
120827	Shield	1

PARTS LIST - TORCH AND CONSUMABLES

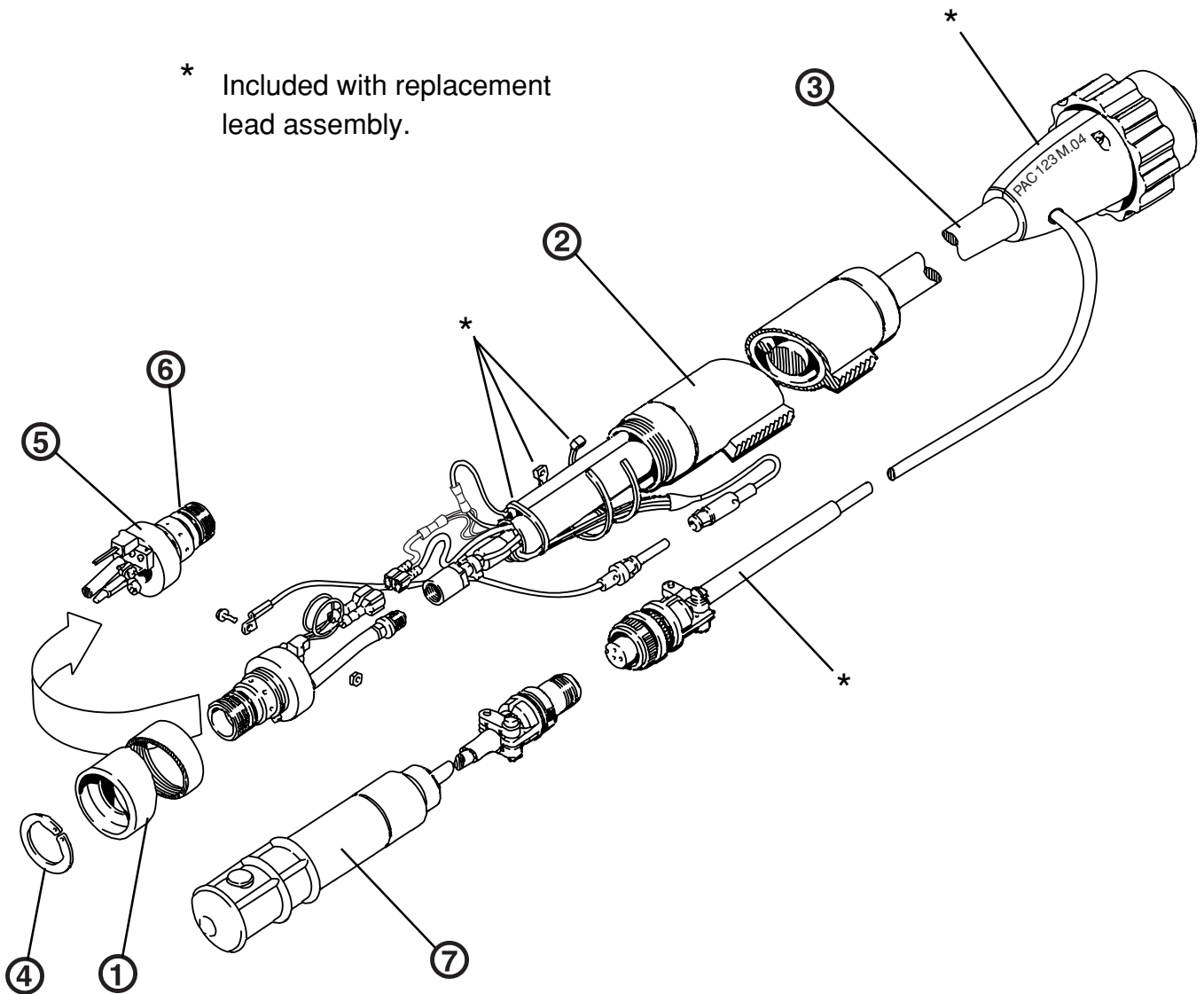

PAC123M Machine Torch Assembly and Leads - With Quick Disconnect

PARTS LIST - TORCH AND CONSUMABLES

Torch Consumables

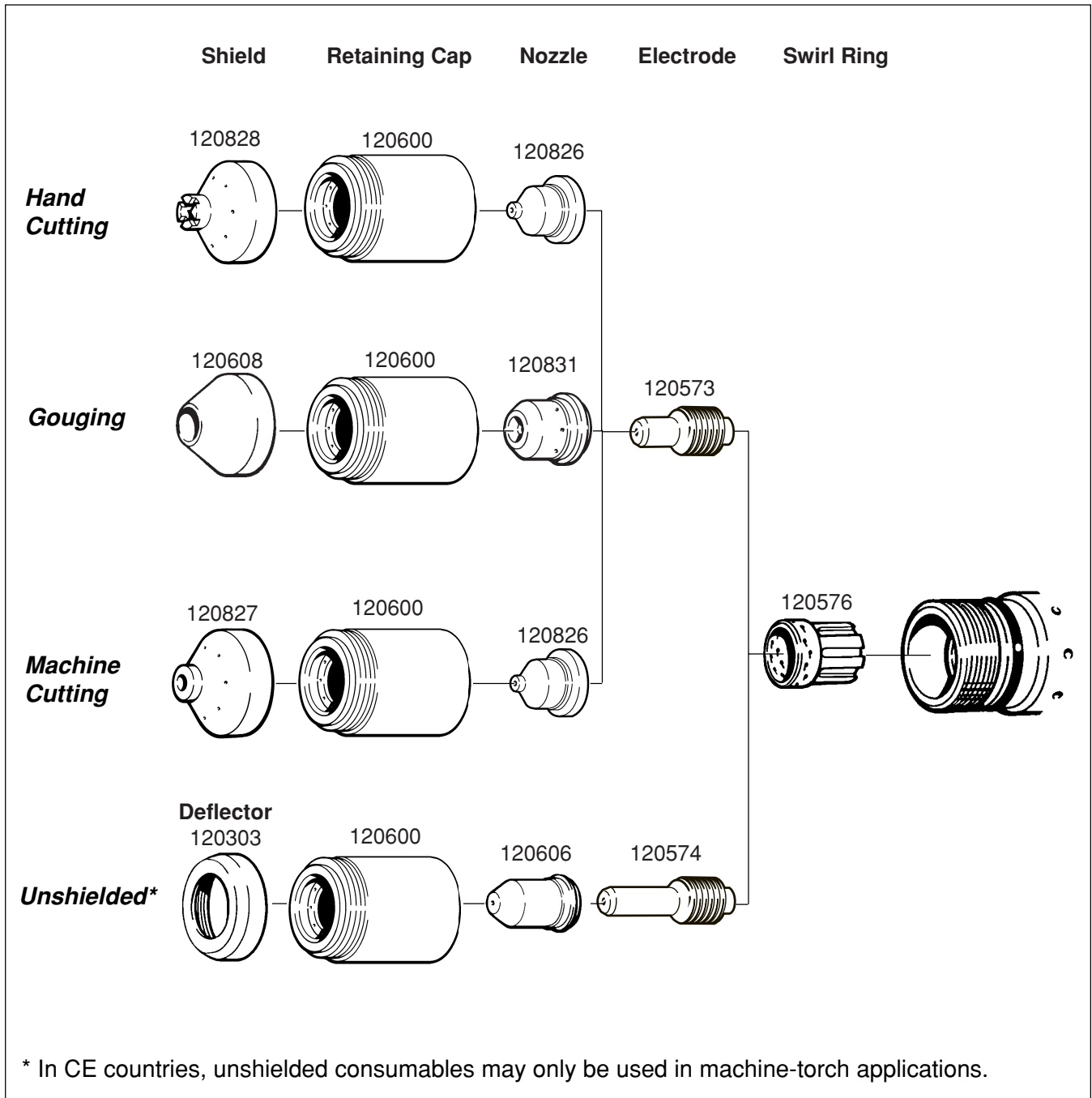

RECOMMENDED SPARE PARTS - PAC123 TORCH

Part Number	Description
001288	Handle, 2 Sides
020620	Sleeve, Machine Torch Position
075339	Screws, P/S, # 4 X 1/2, PH, RND, S/B
086001	PAC123T Hand Torch Assembly with 15 ft / 4.5 m Lead (No Quick Disconnect)
086002	PAC123T Hand Torch Assembly with 25 ft / 7.5 m Lead (No Quick Disconnect)
086003	PAC123T Hand Torch Assembly with 50 ft / 15 m Lead (No Quick Disconnect)
086004	PAC123M Machine Torch Assembly with 15 ft / 4.5 m Lead (No Quick Disconnect)
086005	PAC123M Machine Torch Assembly with 25 ft / 7.5 m Lead (No Quick Disconnect)
086006	PAC123M Machine Torch Assembly with 50 ft / 15 m Lead (No Quick Disconnect)
086023	PAC123T Hand Torch Assembly with 15 ft / 4.5 m Lead (with Quick Disconnect)
086024	PAC123T Hand Torch Assembly with 25 ft / 7.5 m Lead (with Quick Disconnect)
086025	PAC123T Hand Torch Assembly with 50 ft / 15 m Lead (with Quick Disconnect)
086026	PAC123M Machine Torch Assembly with 15 ft / 4.5 m Lead (with Quick Disconnect)
086027	PAC123M Machine Torch Assembly with 25 ft / 7.5 m Lead (with Quick Disconnect)
086029	PAC123M Machine Torch Assembly with 50 ft / 15 m Lead (with Quick Disconnect)
120570	Hand Torch Main Body with Safety Switch
120583	Machine Torch Main Body with Safety Switch
128374	Replacement Machine Torch Lead, 15 ft / 4.5 m (No Quick Disconnect)
128375	Replacement Machine Torch Lead, 25 ft / 7.5 m (No Quick Disconnect)
128376	Replacement Machine Torch Lead, 50 ft / 15 m (No Quick Disconnect)
128377	Replacement Hand Torch Start Switch (switch and wire splices)
128572	Replacement Machine Torch Lead, 15 ft / 4.5 m (with Quick Disconnect)
128573	Replacement Machine Torch Lead, 25 ft / 7.5 m (with Quick Disconnect)
128574	Replacement Machine Torch Lead, 50 ft / 15 m (with Quick Disconnect)
129475	Replacement Hand Torch Lead, 15 ft / 4.5 m (No Quick Disconnect)
129476	Replacement Hand Torch Lead, 25 ft / 7.5 m (No Quick Disconnect)
129477	Replacement Hand Torch Lead, 50 ft / 15 m (No Quick Disconnect)
129599	Replacement Hand Torch Lead, 15 ft / 4.5 m (with Quick Disconnect)
129600	Replacement Hand Torch Lead, 25 ft / 7.5 m (with Quick Disconnect)
129601	Replacement Hand Torch Lead, 50 ft / 15 m (with Quick Disconnect)

PARTS LIST - TORCH AND CONSUMABLES

Blank

Section 7

WIRING DIAGRAMS

In this section:

Electrical Schematic: 230/400V	013335
Electrical Schematic: 208-240/480V	013337

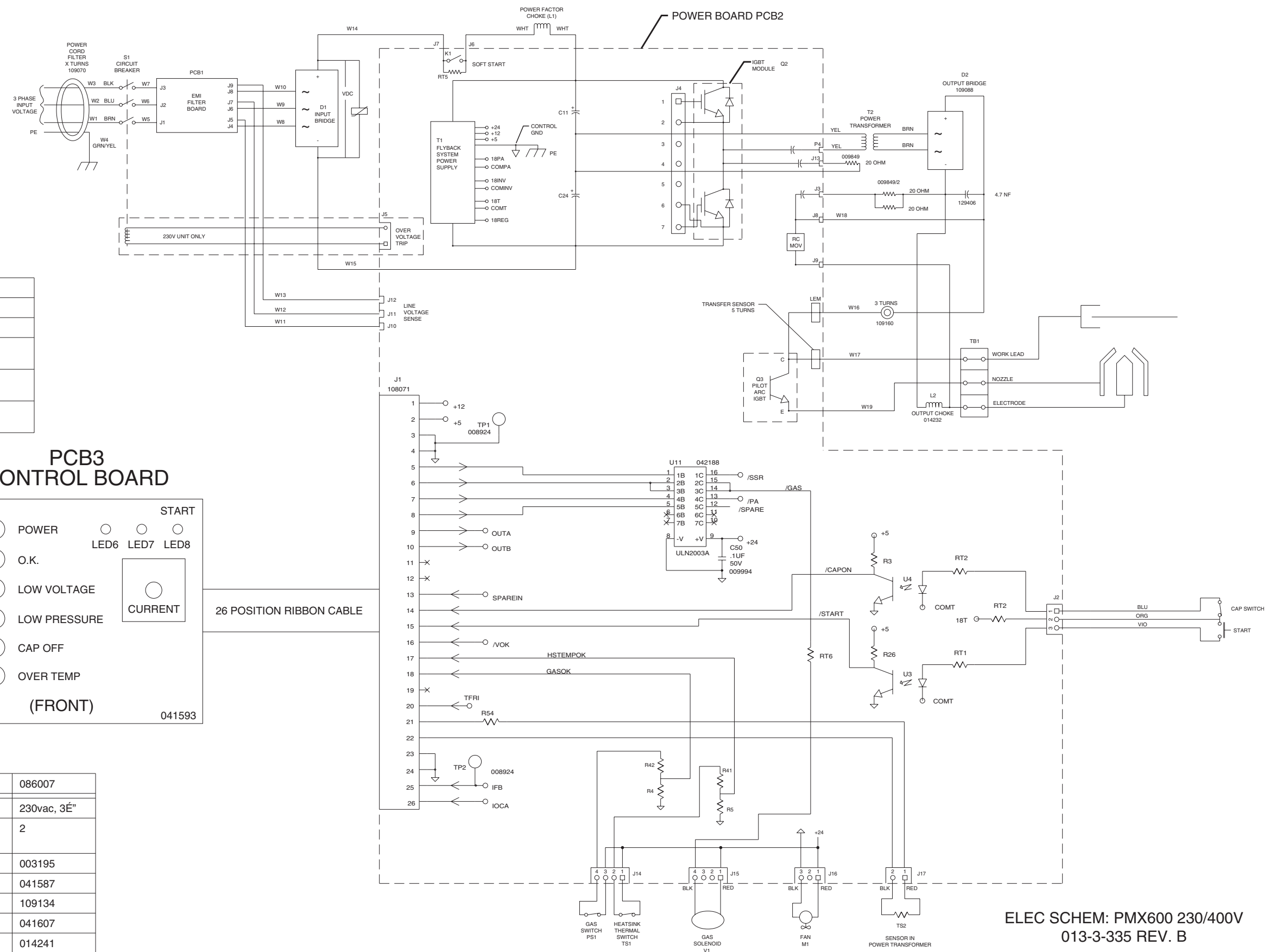

FAULT CODES		
LED7	LED6	STATUS
OFF	OFF	SYSTEM OKAY
OFF	ON	SELF DIAGNOSTICS FAILURE (BLINKING @ 1 SEC. RATE)
ON	OFF	INVERTER SAFETY INTERLOCK (VISIBLE FOR 15 SEC. AFTER EVENT)
ON	ON	TORCH STUCK OPEN (VISIBLE FOR 15 SEC. AFTER EVENT)

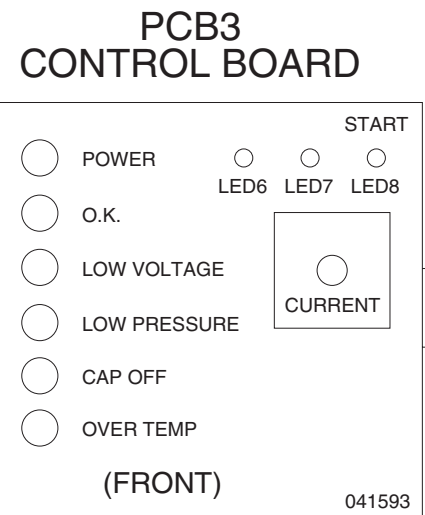

POWER SUPPLY PART #	086000	086007
INPUT VOLTAGE	400vac, 3E"	230vac, 3E"
POWER CORD # TURNS ON TORROID	3	2
CIRCUIT BREAKER (S1)	003193	003195
EMI FILTER BOARD (PCB1)	041566	041587
INPUT BRIDGE (D1)	109090	109134
POWER BOARD (PCB2)	041568	041607
POWER FACTOR CHOKE (L1)	014231	014241
POWER XFR (T2)	014234	014238
BULK CAPS ON POWER BD	009999/2	109118/2
IGBT MODULE (Q2)	109079	109061
TIMING DIAGRAM	013333	013333
VDC	540	310

ELEC SCHEM: PMX600 230/400V
013-335 REV. B

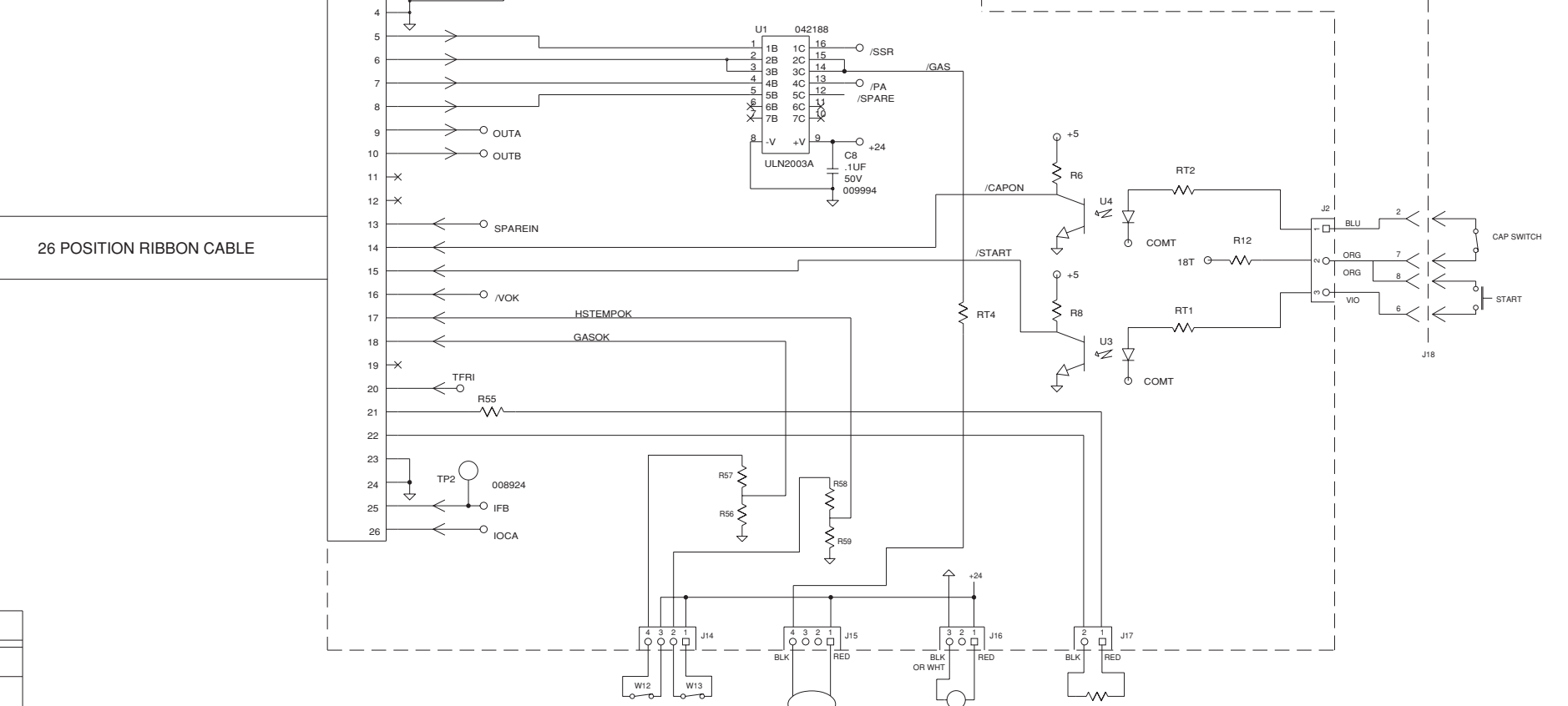
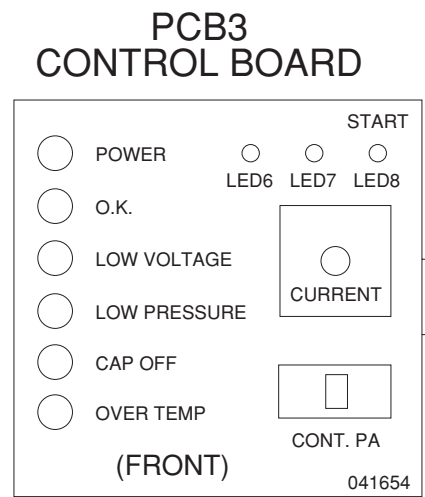
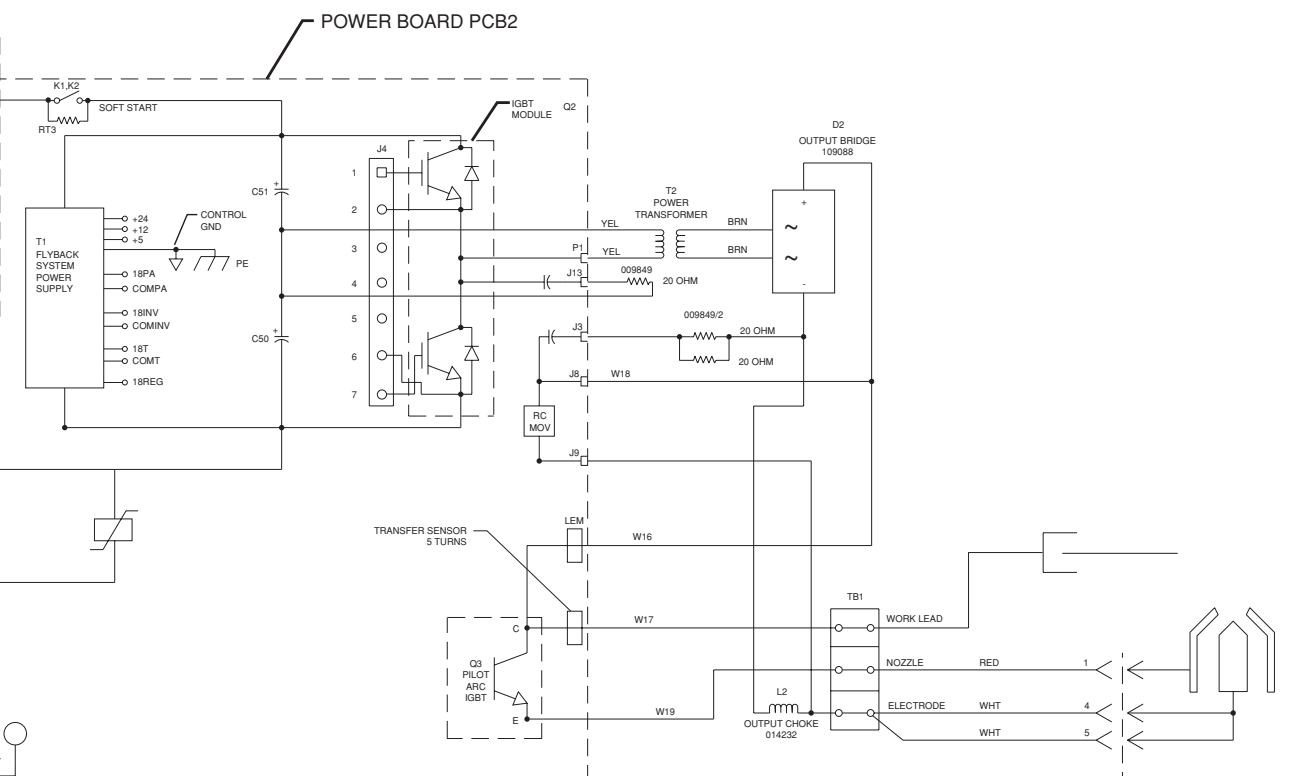
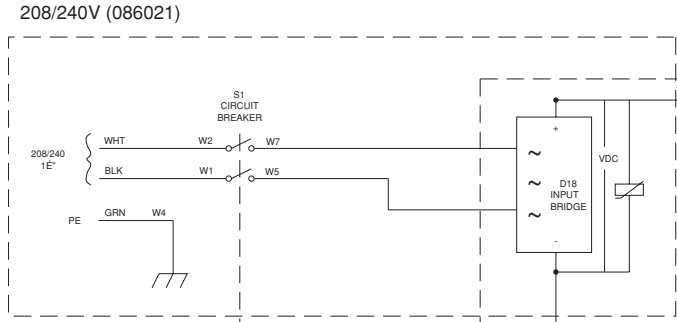
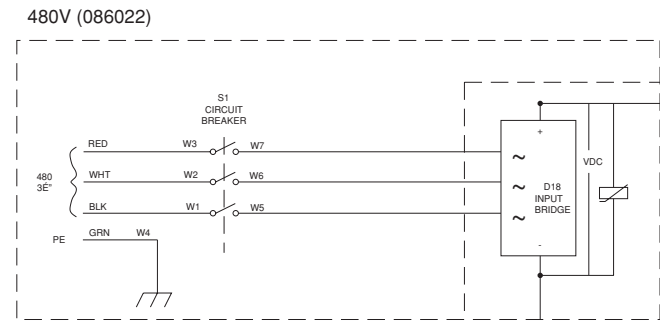

POWER SUPPLY PART #	086021	086022
INPUT VOLTAGE	208/240vac, 1E"	480vac, 3E"
CORD	129530	023519
CIRCUIT BREAKER (S1)	003202	003193
INPUT BRIDGE (D18)	109174	109175
POWER BOARD (PCB2)	041650	041652
POWER XFR (T2)	014251	014252
BULK CAPS	109187/2	109179/2
IGBT MODULE (Q2)	109183	109079
TIMING DIAGRAM	013333	013333
VDC	330	660

FAULT CODES		
LED7	LED6	STATUS
OFF	OFF	SYSTEM OKAY
OFF	ON	SELF DIAGNOSTICS FAILURE (BLINKING @ 1 SEC. RATE)
ON	OFF	INVERTER SAFETY INTERLOCK (VISIBLE FOR 15 SEC. AFTER EVENT)
ON	ON	TORCH STUCK OPEN (VISIBLE FOR 15 SEC. AFTER EVENT)